

Chapter 8.5



LZC hot water systems

This chapter provides guidance for equipment and installation of low or zero carbon sources (LZC) that provide hot water only. Other LZC systems that follow the general principles of this chapter may also be acceptable, subject to specific agreement with NHBC.

This chapter contains the following sections:

8.5.1 Solar thermal hot water systems





Chapter

8.5.1



Solar thermal hot water systems

Systems which convert solar radiation energy to space and/or water heating.

| | | |
|----------|--------------------------------------|----|
| 8.5.1.1 | Compliance | 02 |
| 8.5.1.2 | Provision of information | 03 |
| 8.5.1.3 | System design | 03 |
| 8.5.1.4 | Safe discharge | 04 |
| 8.5.1.5 | Building integration | 04 |
| 8.5.1.6 | Fixing | 04 |
| 8.5.1.7 | Access | 05 |
| 8.5.1.8 | Electrical installation requirements | 05 |
| 8.5.1.9 | Handling and storage | 05 |
| 8.5.1.10 | Handover requirements | 05 |
| 8.5.1.11 | Sequence of work | 05 |

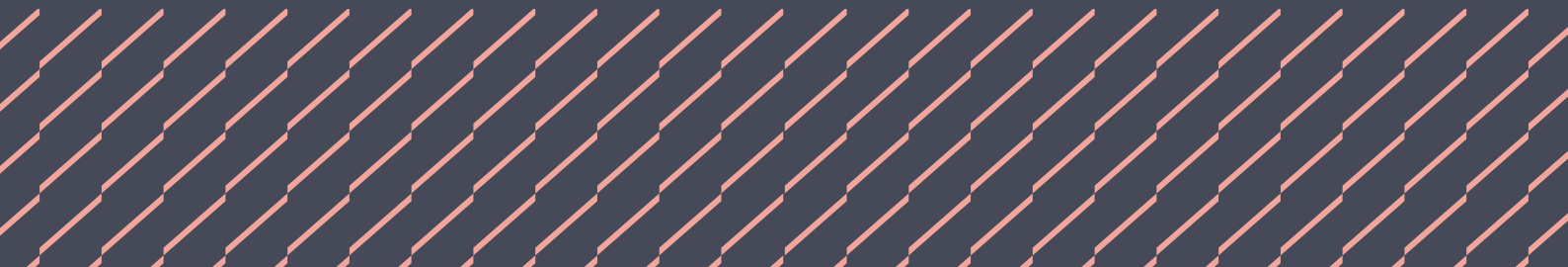
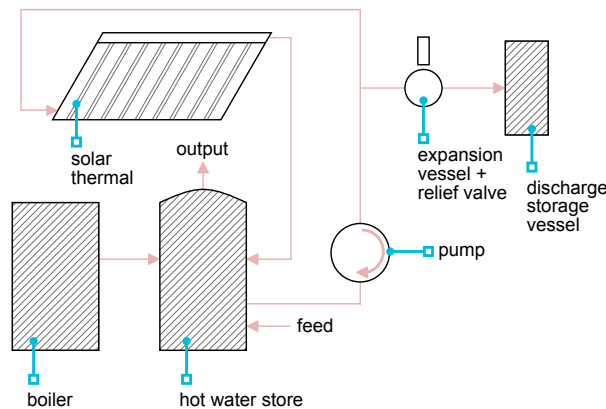

Figure reference table**Figure Reference Table 8.5.1**

| Fig No | Title/Description | Chapter | Page |
|---------------|--------------------------|----------------|-------------|
| Figure 1 | Solar thermal schematic | 8.5.1 | 2 |
| Figure 2 | Solar thermal fixing | 8.5.1.5 | 4 |

Figure 1: Solar thermal schematic



Definitions for solar thermal hot water systems

| | |
|--|--|
| Coastal locations | A site within a distance of 500m from the general coastline of the United Kingdom. |
| Low or zero carbon (LZC) technologies | A term applied to renewable sources of energy, and also to technologies which are significantly more efficient than traditional solutions, or which emit less carbon in providing heating, cooling or power. |
| Performance | The manner or quality of functioning for a material, product or system. |
| Renewable energy | Energy from naturally available sources that can be replenished, including energy from the sun, wind and tides, and from replaceable matter such as wood or other plant material. |

8.5.1.1 Compliance

Also see: Chapter 2.1

Solar thermal hot water systems shall comply with the Technical Requirements. Issues to be taken into account include:

- 1) relevant standards
- 2) product certification
- 3) operative competency.

LZC technologies that comply with the guidance in this chapter will generally be acceptable.

8.5.1.1.1 Relevant standards

Solar thermal hot water systems should comply with relevant standards, including where applicable:

| | |
|-----------------------|--|
| BS EN 12975-1 | Thermal solar systems and components. Solar collectors |
| BS EN 12976-1 | Thermal solar systems and components. Factory made systems |
| BS EN ISO 9806 | Solar energy. Solar thermal collectors. Test methods |
| BRE Digest 489 | Wind loads on roof-mounted photovoltaic and solar thermal systems |
| MCS 004 | Microgeneration Certification Scheme requirements for solar collectors |
| MCS 012 | Solar roof fixing standard |
| MIS 3001 | Microgeneration Installation Standard for solar thermal installation |

8.5.1.1.2 Product certification

Solar thermal hot water technologies should have current certification confirming satisfactory assessment by an appropriate independent authority acceptable to NHBC.

Solar thermal products that are certified through the Microgeneration Certification Scheme (MCS) will generally be acceptable to NHBC. Certification and test documentation should be made available to NHBC upon request.

Other certification bodies or test documentation may be acceptable where they are considered by NHBC to be a suitable alternative.

8.5.1.1.3 Operative competency

Solar thermal hot water systems should be installed by companies, organisations or operatives who are:

- competent and familiar with the system being installed, and
- certified to a standard acceptable to NHBC.
- MCS Certified, or

8.5.1.2 Provision of information

Designs and specifications shall be produced in a clearly understandable format, include all relevant information and be distributed to the appropriate personnel.

Provision of information is important as it allows for energy-efficient use of the building and common methods adopted to prevent overheating.

Clear and fully detailed drawings should be available on site to enable work to be carried out in accordance with the design. Design and specification information should be issued to site supervisors, relevant specialist subcontractors and suppliers, and include the following information:

- fixing schedule
- a full set of current drawings
- indication of which manufacturer and/or installer is responsible for each system and interface
- commissioning schedule
- manufacturers' specifications
- interface details
- on-site testing requirements
- type and spacing of clips and fixings
- type and location of ancillary components, including those used for fire safety and acoustic purposes
- commissioning certificates
- location and size of water storage cisterns and cylinders
- hot water pipe runs.

8.5.1.3 System design

Solar thermal hot water systems shall be designed to ensure satisfactory performance. Issues to be taken into account include:

- | | |
|-------------|------------------|
| 1) location | 3) compatibility |
| 2) system | 4) performance. |

8.5.1.3.1 Location

Solar thermal hot water systems should be correctly located.

Solar thermal collectors, including ancillary components, should be located and identified in accordance with the manufacturer's recommendations.

Solar thermal hot water systems, when sited in coastal locations, should be suitable for the environment. Manufacturers' recommendations should be followed detailing requirements.

8.5.1.3.2 System

Solar thermal hot water systems should be designed in accordance with the manufacturer's recommendations, certification scheme requirements and appropriate standards.

Each system should generally be supplied from one manufacturer as a package, not as individual components or materials. However, where components from more than one manufacturer are used, they should be compatible to ensure satisfactory performance.

Solar thermal systems should be designed to prevent stagnation and damage to the collectors from oversizing.

8.5.1.3.3 Compatibility

Solar thermal hot water systems should be installed so as not to adversely affect the performance of the building to which they are fixed, and in accordance with the manufacturer's recommendations.

Multiple systems should be compatible with each other.

8.5.1.3.4 Performance

Solar thermal hot water systems designed to contribute towards space and water heating should be designed in accordance with the performance requirements in Chapter 8.3 Space heating systems and Clause 8.1.8.

8.5.1.4 Safe discharge

Discharge from solar thermal hot water systems shall terminate safely.

Solar thermal hot water systems should discharge into a storage vessel. The discharge pipework and vessel should be suitable to withstand high temperatures.

8.5.1.5 Building integration

Also see: Clauses 7.2.15, 7.2.17 and Chapter 8.6

Solar thermal hot water system installation shall be securely fixed and not adversely affect the weather resistance of the building.

Foundations and anchor points for stand-alone solar thermal technologies should be designed by an engineer in accordance with Technical Requirement R5 to withstand the structural forces acting upon them.

The structure to which the solar thermal technology is attached should be assessed according to its ability to accept the loadings and prevent detrimental effects arising from movement or vibration.

The design of the structure should take account of:

- the self-weight of the solar thermal components
- imposed loads
- wind loads
- dynamic loading (where relevant).

Notching, drilling or chasing of structural components to accommodate service pipes or cables should either comply with Clause 8.6.2.7 or be designed by an engineer in accordance with Technical Requirement R5.

Fixings, supports, bracketry and mounting frames should:

- accommodate all static and dynamic loads in accordance with the manufacturer's recommendations
- have adequate protection against corrosion (grade 316 stainless steel is recommended for coastal locations)
- be compatible or isolated where two metals are to be joined to prevent bimetallic corrosion.

Figure 2: Solar thermal fixing

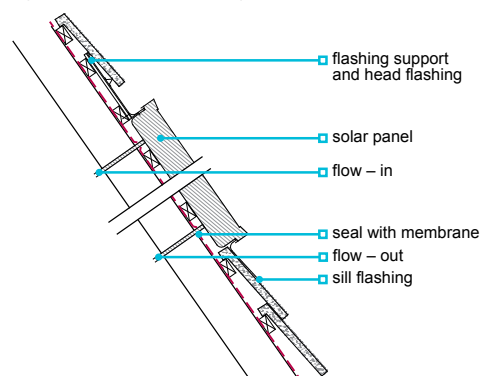

Aluminium and aluminium alloys should not come into contact with cementitious material.

All interfaces between the LZC technology and the building should ensure adequate weather resistance, and be sealed to limit air leakage and prevent moisture from reaching the interior or any part of the structure that could be adversely affected by its presence. The envelope should be weatherproofed using appropriate flashings and fixings. Weatherproofing details that rely solely on sealant are not acceptable.

8.5.1.6 Fixing

Solar thermal hot water systems shall be securely fixed using durable materials.

Fixings should comply with the types listed in Table 1.

Table 1: Materials suitable for fixings

| Fixing material | Guidance |
|-----------------|---|
| Phosphor bronze | NA |
| Silicon bronze | NA |
| Stainless steel | BS EN ISO 3506 |
| Mild steel | Coatings to BS EN ISO 2081, BS EN ISO 2082, BS EN 1461 or other appropriate treatment in accordance with BS EN ISO 12944 or BS EN ISO 14713 |
| Aluminium alloy | BS EN 573 and BS EN 755 |
| Stainless steel | BS EN 10088 |
| Mild steel | BS EN 10346 |
| Other materials | Assessed in accordance with Technical Requirement R3 |

Materials that comply with recognised standards, which provide equal performance to (or better than) those in Table 1, are also acceptable.

The type, size, number, position and fitting tolerance of fixings should be in accordance with the manufacturer's recommendations.

Issues that should be taken into account include:

- the provision of suitable locking nuts and washers
- the isolation of aluminium from cementitious material.
- the isolation of dissimilar metals

8.5.1.7 Access

Appropriate arrangements shall be provided for the purposes of maintenance and removal of permanent equipment.

Access should be provided for solar thermal systems in accordance with the manufacturer's recommendations.

Where permanent equipment is to be installed in a loft or roof void, guidance is provided in Clause 7.2.12.

8.5.1.8 Electrical installation requirements

Also see: Clause 8.1.6

The electrical installation shall be in accordance with relevant regulations.

Electrical installations should comply with *BS 7671 Requirements for Electrical Installations*.

The electrical installation should be capable of being isolated from all other electrical sources when required, for maintenance or testing.

8.5.1.9 Handling and storage

Materials, products and systems shall be handled, stored and protected in a satisfactory manner to prevent damage, distortion, weathering and degradation.

Solar thermal systems should be:

- transported, lifted, handled and stored in accordance with the manufacturer's recommendations
- delivered in sequence to avoid storage
- protected to avoid the risk of damage.

8.5.1.10 Handover requirements

Detailed information and instructions shall be provided to the homeowner.

The pack of information provided to the homeowner should include:

- user instructions for the systems installed
- contact details for the manufacturer and installer
- key components installed
- a completed manufacturer's certificate from an acceptable independent assessment organisation, MCS or suitable alternative
- maintenance and servicing requirements
- warranties and/or guarantees
- recommendations should be given on how solar collectors should be protected from distortion if not filled with solar fluid in line with the manufacturer's recommendations.

8.5.1.11 Sequence of work

Solar thermal hot water systems shall be installed in accordance with a suitable schedule.

To ensure performance, solar thermal hot water systems and ancillary components should be installed in a logical and timely sequence in accordance with the manufacturer's recommendations.

Technical Disclaimer

The NHBC Standards are produced by NHBC as guidance solely for our builder customers as to how to interpret the technical requirements in relation to the warranty cover provided by NHBC under its Buildmark, Buildmark Choice, Buildmark Link, Buildmark Solo, Buildmark Connect or any similar product from time to time. It has not been created or intended for distribution or use outside of that purpose. The information contained in the NHBC Standards do not constitute advice and is not to be relied upon by any third party. Nothing in the NHBC Standards is intended to, nor should it be taken to, create any legal or contractual relationship. Any third party who chooses to rely upon the information contained in the NHBC Standards shall do so entirely at their own risk and NHBC accepts no duty of care or liability, however caused, in connection with its use or reliance by any third party.