

Chapter 6.7



Doors, windows and glazing

This chapter gives guidance on meeting the Technical Requirements for doors, windows and glazing, including where coupled door and window frame assemblies are contained within a single storey.

Coupled door and window frame assemblies (including spandrel panels) which are:

- one storey or more in height, or
- not contained between a structural floor and ceiling

should be designed in accordance with Chapter 6.9 Curtain walling and cladding.

This chapter does not provide guidance on compliance with relevant Building Regulations. Work shall comply with all relevant Building Regulations covering:

- weathertightness
- thermal performance
- fire safety
- safety from impact
- ventilation
- security.

| | | |
|--------|--|----|
| 6.7.1 | Compliance | 02 |
| 6.7.2 | Provision of information | 02 |
| 6.7.3 | In-service performance | 03 |
| 6.7.4 | Coupled door and window frame assemblies | 05 |
| 6.7.5 | Glazing | 06 |
| 6.7.6 | Security | 08 |
| 6.7.7 | Timber doors and windows | 08 |
| 6.7.8 | Non-timber doors and windows | 09 |
| 6.7.9 | Ironmongery | 10 |
| 6.7.10 | Material storage and protection | 10 |
| 6.7.11 | Installation | 11 |
| 6.7.12 | Completed work | 13 |
| 6.7.13 | Further information | 13 |

Figure reference table**Figure Reference Table 6.7**

| Fig No | Title/Description | Clause | Page |
|---------------|--|---------------|-------------|
| Figure 1 | Water bar and weatherboard to external doors | 6.7.3.1 | 3 |
| Figure 2 | Throating to window sill — cavity masonry wall | 6.7.3.1 | 3 |
| Figure 3 | Throating to window sill — stone sill | 6.7.3.1 | 4 |
| Figure 4 | Checked rebate | 6.7.3.1 | 4 |
| Figure 5 | Treatment of cut ends | 6.7.10.2 | 10 |
| Figure 6 | Framing members | 6.7.11.2 | 11 |

Definitions for this chapter

| | |
|---|--|
| Air and vapour control layer (AVCL) | Continuous layer of material with a high resistance to water vapour to control the movement of air and water vapour. |
| Air barrier | A barrier to control air leakage into and out of the building envelope (for framed walls, this is usually in the form of a membrane). |
| Breather membrane | Continuous layer of material with a low resistance to water vapour to allow vapour movement but impermeable to water. |
| Building envelope | External wall or roof construction that separates the habitable parts of a building from the external environment. |
| Coupled door and window frame assemblies | A glazed wall formed by joining pre-assembled doors and/or windows together (the window frames may be supported directly by brackets fixed to the primary structure or may be supported by horizontal and vertical framing members). |
| Doors | A complete door assembly, assembled on site or delivered as a complete assembly, consisting of the door frame, door leaf or leaves, essential hardware and any integral side panel or fanlight. |
| Fixings | Component that is used to secure separate parts of a window or door to each other, to secure an item of hardware to a window or door part, or to secure a completed window or door into the structure of a building. |
| Frames | Outer frame, mullion and transom components of doors and windows. |
| Glazing | Glass component of a door or window. |
| Glazing material | A material which provides a bedding for the glass and forms a joint between the glass and frame (including glazing compounds, sealants, putties, glazing strips and tapes, and gaskets). |
| Impregnated foam tapes | Impregnated foam weatherproofing strip: flexible, elastic, preformed material that constitutes a linear seal when compressed. |
| Insulating glass unit (IGU) | Assembly consisting of at least two panes of glass, separated by one or more spacers, hermetically sealed along the periphery, mechanically stable and durable. |
| Sealant | Wet applied compound, applied in an unformed state to a joint which seals it by adhering to appropriate surfaces within the joint. |
| Structural opening | Opening in an external wall or roof into which a window or door is to be installed. |
| System manufacturer | Company that designs, manufactures and supplies a system. |
| Thermal bridging | Weak points (or areas) in the building envelope that allows heat to pass through more easily. |
| Weathertightness | Performance in respect of air permeability, watertightness and resistance to wind load. |
| Window | Building component or multiple components for closing an opening in a wall or roof that may admit light and/or provide ventilation. |

6.7.1 Compliance

Also see: Chapter 2.1

Doors, windows and glazing shall comply with the Technical Requirements.

Doors, windows and glazing which comply with the guidance in this chapter will generally be acceptable.

6.7.2 Provision of information

Designs and specifications shall be produced in a clearly understandable format, include all relevant information and be distributed to appropriate personnel.

Design and specification information should be issued to site supervisors, relevant specialist subcontractors and suppliers.

6.7.3 In-service performance

Doors and windows shall be designed and specified to ensure adequate in-service performance. Issues to be taken into account include:

- | | |
|--------------------------------|-----------------------------------|
| 1) weathertightness | 3) accommodating thermal movement |
| 2) minimising thermal bridging | 4) operation and strength. |

6.7.3.1 Weathertightness

The following documents should show weathertightness performance classifications of doors and windows:

- CE/UKCA marking in accordance with BS EN 14351-1
- appropriate third-party product certification.

The performance classification levels should be appropriate for the site exposure conditions.

For doors and windows into low-rise housing, the suitability of weathertightness performance classification levels for the site exposure conditions may be determined according to the procedure in BS 6375-1.

Higher levels of performance should be specified for doors and windows into medium- and high-rise buildings as remedial works in the event of water leakage are likely to be more difficult. Windows in high-rise buildings may also be exposed to higher levels of wind-driven rain.

The satisfactory weathertightness performance of doors and windows also depends on appropriate detailing of interfaces with the surrounding building envelope. The interface between any window or door and its surround should be a robust detail that is easy to understand at the construction stage. It should be evident how it should be constructed and should be easy to inspect and/or test.

The head of frames should be set back from the edge of the lintel/cavity tray, and sills should project at least 25mm beyond the wall face (further guidance on sill projections to rendered walls can be found in Clause 6.11.7).

Where doors and windows are incorporated into structural openings of timber framed walls, breather membranes should be used to provide a secondary water barrier to prevent entrapping water vapour and causing interstitial condensation within the wall.

Accessible thresholds should be detailed to meet relevant Building Regulations, precautions should be taken to prevent water ingress, such as:

- correctly detailed DPC/DPM arrangements
- provision of an external drainage channel/slot to door thresholds
- nominal falls provided to external surfaces to drain water away from the threshold.

Checked rebates should be used in:

- Scotland
- Northern Ireland
- Isle of Man
- areas where the exposure to driving rain is very severe (severe/very severe exposure when building using timber frame).

Alternatively proprietary cavity closers which hold a satisfactory assessment by an appropriate independent technical approvals authority, accepted by NHBC, for the exposure zone may be acceptable.

Notes

1. Many manufacturers supply doors and windows which exceed the recommended classifications in BS 6375-1, commonly Class 9A (600Pa) for watertightness and Class 4 (600Pa) for air permeability. The use of doors and windows with higher levels of performance will reduce the risk of leakage.
2. Experience suggests that testing for watertightness at 25% of the design wind load gives satisfactory performance, provided that the installation is carried out correctly.

Figure 1: Water bar and weatherboard to external doors

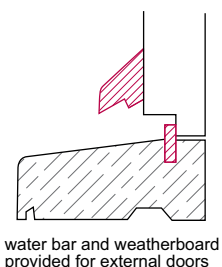
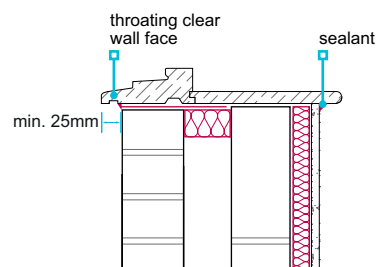

Figure 2: Throating to window sill — cavity masonry wall



Note

1. For guidance on sill projections to rendered walls, see Clause 6.11.7

Figure 3: Throating to window sill — stone sill

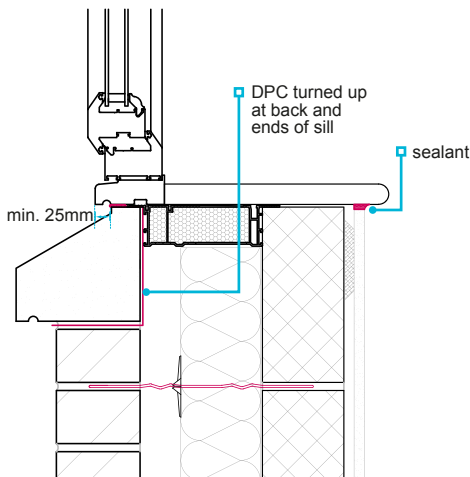

Note

1. For guidance on sill projections to rendered walls, see Clause 6.11.7

6.7.3.2 Minimising thermal bridging

The interface between any door/window and its surround should be designed to minimise the effects of thermal bridging and risk of condensation.

In cavity masonry construction, insulated cavity closures should be built into the structural opening and cavity wall insulation tightly abutted to prevent gaps in the insulation.

Doors and windows should be positioned within the structural opening to maintain continuity of the insulation layer of the building envelope.

Note

1. For doors, reinforced cavity closures may need to be used at thresholds.

6.7.3.3 Accommodating movement

Expansion and contraction of frames is to be expected due to temperature fluctuations. To prevent frames from distorting, a gap around the perimeter of the frame and the structural opening should be provided.

The gap size depends on the frame material and the structural opening size and should be selected in accordance with Table 1.

Table 1: Recommended gaps between the frame and structural opening

| Material | Structural opening size and recommended gap size | | |
|-------------------|--|-------------------|-------------------|
| | Up to 1.5m | From 1.5m to 3.0m | From 3.0m to 4.5m |
| PVC-U — white | 10 | 10 | 15 |
| PVC-U — non-white | 15 | 15 | 22 |
| Timber | 10 | 10 | 10 |
| Steel | 8 | 10 | 12 |
| Aluminium | 10 | 10 | 15 |

Dimensions in mm

The perimeter gap should be sealed with a suitable material which is able to resist water penetration and prevent air leakage whilst accommodating any differential movement requirements.

Where silicone sealants are used they should be applied to a closed cell polyethylene foam backing strip to control the depth of the joint, force the sealant against the sides of the joint during application and aid tooling of the sealant.

When applying sealant into a:

- parallel joint, a width to depth ratio of between 1:1 and 2:1 should be observed
- fillet joint, a minimum 6mm contact to non-porous and 10mm to porous substrate should be achieved.

When impregnated foam tapes are used for perimeter sealing, over sealing with a wet sealant is not usually required. Manufacturers' instructions and product certifications should be followed.

For doors and windows incorporated into the structural openings of timber frame walls, opening and closing gaps should be provided around the frames in accordance with Chapter 6.2 External timber framed walls to allow for the thermal movement of frames and structural movement of the timber frame.

Figure 4: Checked rebate

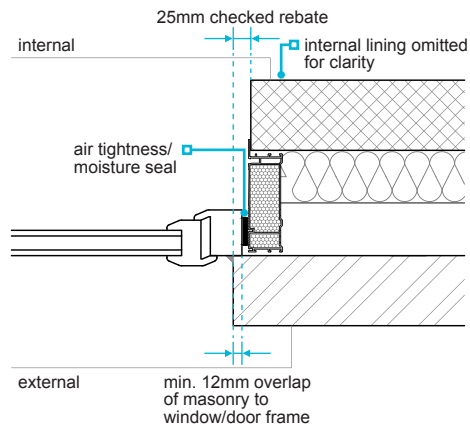

Further guidance on sealants is provided in the following standards:

- BS 6093 Design of joints and jointing in building construction. Guide
- BS 6213 Selection of construction sealants. Guide
- BS EN ISO 11600 Building construction. Jointing products. Classification and requirements for sealants.

6.7.3.4 Operation and strength

Doors, windows and their fittings should be adequate to withstand operational loads. Characteristics and classes of performance should be in line with the relevant class of window or doorset as defined in Annex A of BS 6375-2.

6.7.4 Coupled door and window frame assemblies

Coupled door and window frame assemblies shall be designed and installed to provide adequate in-service performance. Issues to be considered include:

- | | |
|-------------------------|-------------------------------------|
| 1) system design | 4) movement accommodation |
| 2) weathertightness | 5) thermal performance |
| 3) structural integrity | 6) site testing for watertightness. |

Coupled door and window frame assemblies within the scope of this clause are contained within a single storey. Coupled door and window frame assemblies (including spandrel panels) which are one storey or more in height, or not contained between a structural floor and ceiling should be designed in accordance with Chapter 6.9 Curtain walling and cladding.

6.7.4.1 System design

Coupled door and window frame assemblies should be supplied as a standard system comprising only of components designed and detailed by the system manufacturer.

6.7.4.2 Weathertightness

Jointing details should be designed on the principle of two lines of defence with flexible inner and outer seals. The cavity between the seals should be drained to remove any water that bypasses the outer seals.

Weathertightness of coupling joints may be adversely affected by deflections under wind load. Weathertightness of coupling joints should be demonstrated by appropriate laboratory testing of an assembly.

Testing should be undertaken by a UKAS accredited test laboratory. During testing, there should be no leakage onto the internal face of the system at any time.

On completion of the test, there should be no standing water in locations intended to remain dry. Any remedial modifications to the system that are made to pass the test should be reported and incorporated into the installed system.

To avoid difficulty in interpreting the results, it is good practice to agree which materials and zones within the system may be allowed to get wet.

Alternative jointing details should not be used unless they have been proven by testing. The interface between the assembly and the surrounding building envelope should be a robust detail that is easy to understand at the construction stage. It should be evident how the coupling and interface details are to be constructed and should be easy to inspect and/or test.

6.7.4.3 Structural integrity

Coupled door and window frame assemblies should be designed as an engineered system to support their self-weight, resist and safely transfer imposed loads back to the supporting structure.

Windows tested and classified to BS EN 14351-1 are subjected to wind load tests; however, as the perimeter of the window is supported by the test box, the response of the perimeter frame to wind load will not have been fully assessed.

The perimeter frame of the window used in an assembly needs to be able to resist the wind load in bending or the joining component needs to provide support and contribute to the overall stiffness of the system in resisting deflection arising from wind pressure and other loadings, including accidental impact.

For window assemblies, it is recommended that the main structural members of the assembly satisfy class B for which the allowable deflection is span/200 under the design wind load in both positive and negative directions. This is the limit which applies for curtain wall mullions in BS EN 13830.

6.7.4.4 Movement accommodation

As window assemblies are larger than individual windows, the amount of movement to be accommodated is also likely to be greater. Coupling joints and interfaces with the surrounding construction should be designed to accommodate thermal expansion/contraction of the frames and movement of the structure, whilst remaining weathertight.

6.7.4.5 Thermal bridging

Coupling joints, brackets and fixings may create additional heat flow paths resulting in low surface temperatures, increasing the risk of surface condensation.

Coupling joints and interfaces with the supporting structure should be designed to minimise the effects of thermal bridging and risk of condensation, including the appropriate use of thermal breaks.

The thermal assessments of linear coupling joints and interfaces with the supporting structure should be checked to assess the risk of surface condensation.

The assessments should confirm that, under normal operating conditions, condensation does not form on the visible interior surfaces of any framing members or glazing.

6.7.4.6 Site testing for watertightness

To check the workmanship of the installation has not compromised the performance of the system in any way, on-site watertightness testing of coupling joints should be carried out by a UKAS accredited test laboratory using the Centre for Window and Cladding Technology (CWCT) hose test method for water penetration.

A minimum of 5% by length of all critical coupling joints should be tested. Where coupled assemblies of the same type are to be installed across a development, a minimum of two installations should be tested.

For phased developments, the minimum testing applies to each phase.

Testing should be carried out on the first installation on any development or phase before progressing with further installations.

On-site testing may be increased in areas of the UK that are expected to be subjected to severe weather exposure.

If on-site watertightness testing reveals problems with workmanship, these problems should be addressed, and additional testing carried out to confirm satisfactory watertightness performance is achieved before progressing further with the installation.

6.7.5 Glazing

Also see: Glass and Glazing Federation — Safety and security glazing

The method of glazing shall ensure adequate in-service performance. Issues to be considered include:

- | | |
|-----------------------------|----------------------------------|
| 1) standards | 4) glazing systems |
| 2) performance requirements | 5) condition before installation |
| 3) insulating glass units | 6) site glazing. |

6.7.5.1 Standards

Glazing and materials should conform to relevant British Standards as shown in Table 2.

Table 2: Relevant British Standards for glazing

| Standard/Specification Number | Standard/Specification Name |
|-------------------------------|--|
| BS EN 1279-5 | Glass in building. Insulating glass units — Product standard |
| BS EN 572-9 | Glass in building. Basic soda lime silicate glass products — Evaluation of conformity/Product standard |
| BS EN 14449 | Glass in building. Laminated glass and laminated safety glass. Evaluation of conformity/Product standard |
| BS EN 12150-2 | Glass in building. Thermally toughened soda lime silicate safety glass — Evaluation of conformity/Product standard |
| BS EN 1096-4 | Glass in building. Coated glass — Product standard |

6.7.5.2 Performance requirements

Glazing should be selected to meet applicable design and performance requirements in accordance with BS 6262-1.

The type, thickness and size of glass should be selected to provide an appropriate degree of safety, considering the intended use.

Safety glass for use in critical locations should be marked as follows:

- the manufacturer's trademark or name
- the standard number for the type of glass, eg BS EN 14449 laminated glass
- the impact performance classification, eg 1, 2, 3 to BS EN 12600.

The design loads acting upon the glazed area should be determined in accordance with BS EN 1991-1-1, BS EN 1991-1-3 and BS EN 1991-1-4. The type, thickness and size of glass should be specified to suit the design wind loads.

Bath and shower enclosures should comply with *BS EN 14428 Shower enclosure-functional requirements and test methods*.

6.7.5.3 Insulating glass units

Insulating glass units should:

- be CE/UKCA marked in accordance with BS EN 1279
- hold appropriate third-party certification, eg BSI Kitemark
- be checked to ensure they comply with the design, including glass type, gas filling, edge seal type and dimensions
- have a dual seal or a single seal of hot melt butyl and desiccant in at least one long and one short section of the spacer bar.

6.7.5.4 Glazing systems

Drained and vented systems

Drained and vented systems should be used for site-fixed insulating glass units (IGUs) and where units greater than 1m² are used. These systems allow moisture that enters the glazing channel between the frame and the edge seal of the insulating glass unit to drain away and prevent long-term moisture contact with the edge seal.

To achieve the optimum service life of insulating glass units, the following basic principles should be adopted in the design of drained and vented systems:

- **Removal of moisture:** Frames should have adequate drainage and ventilation through holes, slots or channels for the rapid removal of any water that may enter the glazing rebate.
- **Clearance:** A minimum 5mm edge clearance should be provided between the glass edge and frame to prevent frame-to-glass contact, ensure drainage, and allow for differential thermal expansion of the insulating glass unit and frame. For very well-drained and ventilated frames, the clearance can be reduced for the side and top rebates, to a minimum of 3mm in the case of glass lengths up to 2m.
- **Edge cover:** A minimum edge cover of 12mm should be provided to keep the spacer below the sight line and to protect the edge seal from sunlight.
- **Rebates:** The rebate height should allow for tolerances in both the frame size and insulating glass unit size to ensure the minimum edge clearance and minimum edge cover requirements are met. The width of the rebate platform should provide the required front and back clearances, and ensure sufficient contact of the glazing beads onto the platform. The width of the rebate platform should be equal to the sum of the front and back clearances, the nominal thickness of the insulating glass unit, the width of the bead, and an allowance for the tolerances on insulating glass unit and bead thicknesses.
- **Beads:** Should have an installed height equal to the rebate height. Timber beads for timber frames should have a width in contact with the rebate platform greater than the height, to enable firm fixing of the bead to be achieved. The bottom bead should project slightly past the rebate edge. Screw fixings for timber beads should be located a minimum of 75mm from each corner and spaced at no more than 200mm centres. If pins are used, they should be twice the height of the beads and located a minimum of 50mm from each corner and spaced at no more than 150mm centres. Beads for metal and plastic frames should be fixed in accordance with the manufacturer's recommendations to securely retain the insulating glass unit and the glazing seals.
- **Compatibility:** Glazing material should be compatible with frame finishes and glazing unit seals in accordance with the manufacturer's recommendations. Linseed oil-based putty should not be used in the installation of laminated glass or insulating glass units.

Fully bedded systems

Fully bedded systems are acceptable for factory glazing only where the insulated unit is less than 1m², and should:

- comply with the relevant parts of BS 8000, BS 6262 and BRE Digest 453
- not have gaps around the perimeter of the insulating glass unit.

6.7.5.5 Condition before installation

When insulating glass units are stored prior to being installed, they should be:

- protected from direct sunlight to avoid thermal stress
- stored in dry conditions
- provided with adequate support to prevent distortion or bowing.

A visual inspection of glass and insulating glass units should be undertaken for signs of defects which could lead to premature failure. Signs of defects include:

- water accumulation between sheets
- edge damage or scratching.

6.7.5.6 Site glazing

Site glazing should be in accordance with the frame design and undertaken by installers who are appropriately trained and conversant with good glazing practice.

The following features should be checked before glazing:

- drainage and ventilation holes or slots are present, are of a suitable size and are free from obstructions such as fabrication swarf, etc
- ventilation and the free flow of water to holes and slots are not impeded by setting and location blocks, external bead retention lips or glazing materials
- as water can be present in the glazing rebate, screw fixing holes and frame joints are adequately sealed against water ingress
- a minimum 5mm edge clearance is provided around the perimeter of the insulating glass unit to prevent glass to frame contact, to ensure drainage and allow for differential thermal expansion
- gaskets or strip materials supplied cut to size are the correct length to ensure that there are no gaps at the corners.

Note

1. Further guidance can be found in the Glass and Glazing Federation (GGF) System Design and Glazing Considerations for Insulating Glass Units (IGUs).

6.7.6 Security

Doors, door frames, windows and locks shall be designed and specified to improve their resistance to unauthorised entry.

Security in dwellings should be provided in accordance with the design and meet the requirements of relevant Building Regulations.

6.7.7 Timber doors and windows

Also see: Chapters 3.3 and 9.5

Timber and wood-based materials shall be of suitable quality and be naturally durable or suitably treated. Issues to be considered include:

- 1) quality assurance
- 2) classification and use
- 3) drying shrinkage
- 4) preparation and finish.

6.7.7.1 Quality assurance

Manufacturers of timber doors and windows should hold appropriate third-party certification to assure the fitness for purpose and quality of their products.

6.7.7.2 Classification and use

Timber windows should:

- conform to BS 644
- have a minimum 15mm rebate where double glazed units are to be installed.

Timber and wood-based materials should conform with the relevant requirements of BS EN 942 as shown in Table 3.

Table 3: Relevant requirements of BS EN 942

| Component | Requirement |
|----------------------------|----------------------|
| Glazing beads | European Redwood |
| Casements and sash windows | J classes |
| All other elements | Table 1 of BS EN 942 |

In England, Wales, Northern Ireland and the Isle of Man, planted stops are not permitted on frames to external doors.

External doors should be 42.5mm minimum (44mm nominal) in thickness.

6.7.7.3 Drying shrinkage

To minimise drying shrinkage, the moisture content of joinery, when fixed, should not exceed the value given in Table 4.

Table 4: Moisture content of joinery

| Joinery items | Moisture content (%) |
|-----------------------|----------------------|
| Windows and frames | 17 |
| Internal joinery: | |
| Intermittent heating | 15 |
| Continuous heating | 12 |
| Near to a heat source | 9 |

Note

1. On delivery, the moisture content should be within +/-2% of the values specified.

6.7.7.4 Preparation and finish

The following elements of timber doors and windows should be of naturally durable timber or timber pre-treated against fungal decay:

- external door frames
- windows
- timber surrounds to metal windows
- external doors, other than flush doors.

Where material is:

- to be painted, it should be primed before fixing
- to be stained, it should have the first coat applied before delivery to site.

Compatibility between preservative treatment or primer, with glazing compounds, sealants, and finishes, should be checked with the relevant manufacturers.

Prefabricated items should conform with the relevant parts of BS 1186: Part 2, including:

- the fit and construction of joints and moving parts
- the construction of finger joints
- gluing and laminating
- surface finishes.

6.7.8 Non-timber doors and windows

Doors and windows of materials other than timber shall be of suitable quality. Issues to be considered include:

- 1) quality assurance
- 2) standards.

6.7.8.1 Quality assurance

Manufacturers of non-timber doors and windows should hold appropriate third-party certification to assure the fitness for purpose and quality of their products.

6.7.8.2 Standards

Non-timber doors and windows should conform to relevant standards as shown in Table 5.

Table 5: Relevant standards for non-timber doors and windows

| Standard/Specification Number | Standard/Specification Name |
|-------------------------------|---|
| BS 4873 | Aluminium alloy windows and doorsets. Specification |
| BS 6510 | Steel-framed windows and glazed doors. Specification |
| BS 7412 | Specification for windows and doorsets made from unplasticized polyvinyl chloride (PVC-U) extruded hollow profiles |
| BS EN 12608-1 | Unplasticized poly(vinyl chloride) (PVC-U) profiles for the fabrication of windows and doors. Classification, requirements, and test methods — Non-coated PVC-U profiles with light coloured surfaces |
| BS 7414 | Specification for white PVC-U extruded hollow profiles with heat welded corner joints for plastics windows: materials type B |
| BS 8529 | Composite doorsets. Domestic external doorsets. Specification |

6.7.9 Ironmongery

Ironmongery shall be suitable for the intended use.

Ironmongery should be provided in accordance with the design. Materials used for critical functions should comply with the appropriate standards given in Table 6.

Table 6: Relevant British standards for ironmongery

| Standard/Specification Number | Standard/Specification Name |
|-------------------------------|--|
| BS EN 1935 | Building hardware. Single-axis hinges. Requirements and test methods |
| BS 3621 | Lock assemblies operated by key from both the inside and outside of the door |
| BS 8621 | Lock assemblies operated by key from the outside of the door and by handle or thumb turn from the inside of the door |
| BS 10621 | Lock assemblies in which the operating mode can be switched between the normal BS 8621 operating mode and a secure mode in which no egress is possible |
| BS EN 1906 | Building hardware. Lever handles and knob furniture. Requirements and test methods |
| BS EN 12209 | Building hardware. Locks and latches. Mechanically operated locks, latches and locking plates. Requirements and test methods |
| BS EN 1154 | Building hardware. Controlled door closing devices. Requirements and test methods |

Ironmongery for windows should be supplied as follows:

- hinges and fastenings of opening lights of windows should be of a type which prevents them from being opened from the outside when in the closed position
- where the windows are required by relevant Building Regulations to have background ventilation, they may be fitted with trickle vents or some other means of providing ventilation which is controllable and located to avoid undue draughts. Windows with 'night vent' positions are not accepted as meeting this requirement.

Where doors to rooms containing a bath or WC have a securing device, it should be of a type capable of being opened from the outside in an emergency.

In sheltered accommodation, additional special provisions may be needed for all door locks, limiters and other fasteners, to enable wardens to gain access when necessary.

6.7.10 Material storage and protection

Joinery, door and window components shall be adequately protected against damp and decay. Issues to be considered include:

- 1) storage
- 2) cut ends.

6.7.10.1 Storage

Where joinery is stored on site, precautions should include:

- avoiding wetting during unloading
- stacking external joinery on bearers off the ground and covering with waterproof material
- storing internal joinery in a weather-protected condition.

6.7.10.2 Cut ends

Where pre-treated joinery is cut or adjusted on site, the affected surfaces should be re-treated with appropriate preservative in accordance with the manufacturer's recommendations.

Figure 5: Treatment of cut ends

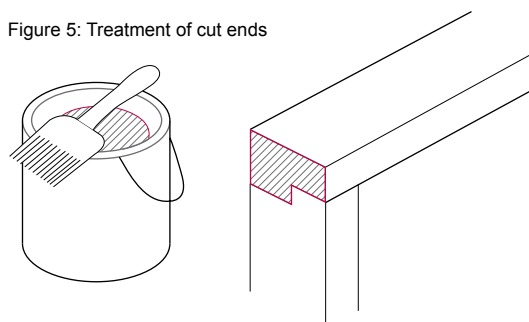

6.7.11 Installation

Doors and windows shall be correctly located and securely fixed. Issues to be considered include:

- | | |
|-------------------------------------|------------------|
| 1) construction tolerances | 5) door hinges |
| 2) workmanship and fixing | 6) window boards |
| 3) hanging doors and opening lights | 7) bay windows. |
| 4) general ironmongery | |

6.7.11.1 Construction tolerances

Construction tolerances for structural openings, doors and windows should be in accordance with Chapter 9.1 A consistent approach to finishes.

6.7.11.2 Workmanship and fixing

Doors and windows should be installed plumb and square within the structural opening in accordance with the manufacturer's instructions. The completed installation should be without twist, racking or distortion of any member so that they operate correctly.

Wherever practical the sides of the frame should be secured in accordance with the recommendations given in BS 8213-4 (see Table 7), using fixings and fixing methods as recommended by the manufacturer. Where it is impractical to follow this guidance, manufacturers recommendations should be followed.

Figure 6: Framing members

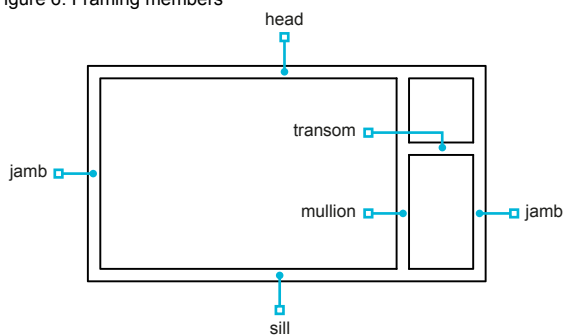
**Note**

1. Head, jamb, mullion, sill and transom fixings positioned in accordance with Table 7.

Table 7: Fixing distances

| Material Specification | Fixing position | | | |
|------------------------|--|---|---|--|
| | Jambs | Sill | Head | Mullion or Transom |
| PVC-U | Fixed within 150mm-250mm from the external corners Minimum of two fixings per jamb and sill, with intermediate fixings maximum 600mm apart | | Fixed within 150mm-250mm from the external corners, with Intermediate fixings maximum 600mm apart ⁽¹⁾ Alternatively, if the head is fixed with PU foam, then the fixings at the head may be as follows: <ul style="list-style-type: none"> • frame width up to 1200mm – no fixings • frame width 1201mm to 2400mm – one central fixing • frame width 2401mm to 3600mm – two equally spaced fixings | Any fixings should be spaced a minimum of 150mm away from the centre line of any mullion or transom they coincide with |
| Timber | Corner jamb fixings should be between 150mm and 250mm from the external corner Minimum of two fixings per jamb, with intermediate fixings maximum 600mm apart | On windows and doorsets over 1800mm wide, central sill fixings should be provided | On windows and doorsets over 1800mm wide, central head fixings should be provided | |
| Aluminium | Corner jamb fixings should be between 100mm and 150mm from the external corner Minimum of two fixings per jamb, with intermediate fixings max. 600mm apart | On windows and doorsets over 1800mm wide a central sill fixing should be provided | On windows and doorsets over 1800mm wide a central head fixing should be provided | Any fixings should be spaced a minimum of 100mm away from the centre line of any mullion or transom they coincide with |

Note

1. Not applicable to French doors, patio doors or bi-fold doors.

Internal door frames and linings should:

- match the thickness of the wall, partitions and finishes
- be blocked off walls wherever possible, to allow for full architraves
- be securely fixed, to prevent curling.

Timber trim should be:

- sufficiently wide to mask joints
- fixed to minimise movement and shrinkage.

Architraves should be:

- parallel to frames and linings
- accurately mitred, or scribed, to fit neatly and tightly
- fixed with an equal margin to each frame member
- fixed securely.

When fixing components:

- nails should be punched below the surface of the timber with holes stopped
- damage should be avoided.

6.7.11.3 Hanging doors and opening lights

Opening lights and door leaves should:

- hang square within the frame or lining
- fit neatly with minimum gaps.

Where a standard flush door is reduced in height, the bottom rail should be replaced where necessary.

6.7.11.4 General ironmongery

Hinges and other ironmongery should be:

- housed neatly and flush with the surface
- supplied with a full set of matching screws.

Locks should:

- turn easily
- have keyholes which are properly aligned.
- not be fitted in mortises too tightly

6.7.11.5 Door hinges

To reduce twisting, doors should be hung on hinges in accordance with Table 8.

Table 8: Summary of appropriate hinges for different door types

| Type of door | Hinges |
|-----------------------------|--|
| External | 1½ pairs x 100mm |
| Internal door | 1 pair x 75mm |
| Fire door | In accordance with the door manufacturer's recommendations |
| Airing or cylinder cupboard | 1½ pairs x 75mm |

6.7.11.6 Window boards

Window boards should:

- have a flat and level top surface
- be of a moisture-resistant grade where MDF is used.
- be fixed close to the frame and adequately secured against twisting and other movement, particularly any back slope towards the frame

6.7.11.7 Bay windows

Bay windows should be:

- adequately supported and secured to the structure to prevent sagging or twisting
- properly linked to DPCs at reveals.

6.7.12 Completed work

Completed work shall be free from damage.

Work should be to an appropriate level of finish for other trades. Finishing trades should not be relied upon to correct untidy work.

Completed work should be protected as follows:

- internal doors should be kept covered with polyethylene or original wrapping
- scaffolding and walkways should be kept away from frames
- door frames and linings should be protected with timber strips or plywood by a minimum of 1m above skirting level
- joinery should be protected from paint splashes and other damage
- thresholds and windowsills should be covered
- temporary coverings should be removed after all other work has been completed and before handover.

6.7.13 Further information

- *Glass and Glazing Federation – Safety and security glazing*

Technical Disclaimer

The NHBC Standards are produced by NHBC as guidance solely for our builder customers as to how to interpret the technical requirements in relation to the warranty cover provided by NHBC under its Buildmark, Buildmark Choice, Buildmark Link, Buildmark Solo, Buildmark Connect or any similar product from time to time. It has not been created or intended for distribution or use outside of that purpose. The information contained in the NHBC Standards do not constitute advice and is not to be relied upon by any third party. Nothing in the NHBC Standards is intended to, nor should it be taken to, create any legal or contractual relationship. Any third party who chooses to rely upon the information contained in the NHBC Standards shall do so entirely at their own risk and NHBC accepts no duty of care or liability, however caused, in connection with its use or reliance by any third party.