

Light steel framed walls and floors

This chapter gives guidance on meeting the Technical Requirements for light steel framed walls and floors and:

- applies specifically to 'warm frame' and 'hybrid construction' using 0.45–4.0mm thick framing
- does not apply to light steel framed walls used in basements.

6.10.1	Compliance	02
6.10.2	Provision of information	02
6.10.3	Structural certification	03
6.10.4	Structural design of load-bearing floors and walls	04
6.10.5	Structural design of infill walls	07
6.10.6	Roofs	07
6.10.7	Steel and fixings	07
6.10.8	Detailing of steel joists	09
6.10.9	Restraint	10
6.10.10	Construction of load-bearing walls and external infill walls	10
6.10.11	Interfaces with staircases	11
6.10.12	Fixing floor decking and ceilings	12
6.10.13	Other design issues	12
6.10.14	Behaviour in relation to fire	13
6.10.15	Acoustic performance	13
6.10.16	Moisture control	13
6.10.17	Insulation	14
6.10.18	Air and vapour control layers	15
6.10.19	Breather membranes	15
6.10.20	Cladding, lining and sheathing boards	16
6.10.21	Wall ties	17
6.10.22	Services	18
6.10.23	Further information	18

Figure reference table

Figure Reference Table 6.10

Fig No	Title/Description	Clause	Page
Figure 1	Joist bearing onto structure with stiffener	6.10.4.1	4
Figure 2	Web cleat connection	6.10.4.1	4
Figure 3	Bolted web-to-web connection	6.10.4.1	4
Figure 4	Lintel arrangement	6.10.4.2	6
Figure 5	Holes and notches	6.10.7.4	8
Figure 6	Web stiffeners for continuous joists over load-bearing intermediate wall	6.10.8.1	9
Figure 7	Joists overlapping on load-bearing intermediate wall	6.10.8.1	9
Figure 8	Floor bracing examples	6.10.8.2	9
Figure 9	Floor edges	6.10.10.1	10
Figure 10	Correct positioning	6.10.10.1	11
Figure 11	Strap anchor example	6.10.10.2	11
Figure 12	Bolt-down anchor example	6.10.10.2	11
Figure 13	Ground level interface	6.10.16.2	14
Figure 14	Allowing for differential movement	6.10.20.1	16
Figure 15	Providing wall ties	6.10.21	17

Definitions for this chapter

Differential movement	Movement between the frame and cladding, eg due to thermal expansion, shrinkage (in concrete masonry) and moisture expansion (in clay masonry).
External infill	Walls which are built between the floors of steel or concrete frames and are designed to resist wind loading and to support the weight of the other wall components. They do not provide stability to the building or resist floor loading. External infill is considered as a secondary structural component.
Hybrid construction	Cavity construction where insulation is installed both between the studs and on the cavity side of the steel frame.
LSF	Light steel frame. In this chapter, 'LSF' refers to construction framing members made from cold-formed profiles 0.45-4.0mm thick. Structural members are typically at least 1.0mm thick.
Primary structural components	Elements of the structure designed to carry and transfer primary loads of the building as a whole, including self-weight, dead loads and live loads.
Secondary structural components	Elements of the structure which do not play a wider role in the structure, but carry loads directly imposed on them (and transfer them to the primary structure) such as self-weight, wind loads, cladding and openings.
Sheathing	Board applied to the outside of the steel frame (installed where required by the design).
Warm frame	Cavity construction where insulation is installed on the cavity side of the steel frame.

6.10.1 Compliance

Also see: Chapter 2.1

LSF structures shall comply with the Technical Requirements.

LSF structures (ie, walls, roofs and floors) that comply with the guidance in this chapter will generally be acceptable.

LSF structures may be:

- structurally independent (primary) and used to form whole buildings, additional storeys, annexes, extensions, penthouses, etc
- infill walls (secondary), or
- bespoke façades (where support may be required from other structural elements).

Construction should be 'warm frame' or 'hybrid' construction, with sufficient insulation outside the steel envelope to ensure that condensation does not occur within the depth of the light steel members.

Stud partitions are considered in Chapter 6.3 Internal walls. LSF systems that do not comply with the principles of this chapter should be assessed in accordance with Technical Requirement R3.

Where the components of the LSF cannot be inspected on site (eg closed panels or fitted out volumetric or modular units) the system should be treated as a proprietary building system under Technical Requirement R3 and subject to assessment by an appropriate independent technical approvals authority or be assessed under the NHBC System Review service – see www.nhbc.co.uk/systemreview.

6.10.2 Provision of information

Designs and specifications shall be produced in a clearly understandable format, include all relevant information and be distributed to all appropriate personnel.

Clear and fully detailed drawings should be available on site to enable work to be carried out in accordance with the design. Designs and specifications should be issued to site supervisors, relevant specialist subcontractors and suppliers, and include:

- a full set of drawings and material specifications
- a typical wall build-up, including wall ties, breather membranes, sheathing and vapour control layers, where applicable
- fixing schedules and details of each connection that is to be made on site
- details of connections with other building elements, including roofs, floors and openings
- information on integration of services and work of subsequent trades
- positions and materials for fire stops and cavity barriers in accordance with relevant Building Regulations
- the number and spacing of bolts, screws and rivets
- the manufacturer's recommendations relating to proprietary items
- details of how wall panels are to be fixed to the substructure, adjacent panels, and floor and roof framing
- the specification for each type of fixing, including corrosion protection.

6.10.3 Structural certificationContact us: business-support@nhbc.co.uk

The LSF system shall be adequately tested and certified. The design of superstructures with primary structural components formed from LSF shall be checked by an NHBC registered LSF certifier.

Primary structural components formed from LSF require two-stage certification confirming that both the system and the project have been checked. External infill does not require Stage 1 and 2 certification (see Clause 6.10.5).

Stage 1 — system certification

NHBC requires manufacturers of LSF systems, which form primary structural components, to submit a system manual to the Steel Construction Institute (SCI) for assessment. The manufacturer is the company which assembles the steel frame sections to form the wall and/or floor panels. If in doubt, consult NHBC Standards, Innovation and Research.

The manual should contain the information described in Table 1. Further performance issues may be considered at the discretion of SCI and the manufacturer (see Table 7).

Table 1: Items included in the system manual

Topic	Description
Description of system	<ul style="list-style-type: none"> • key features
Application	<ul style="list-style-type: none"> • usage, eg maximum number of storeys and type of cladding
Durability	<ul style="list-style-type: none"> • demonstrate that design life is at least 60 years (including environment category) • grade of steel • corrosion protection • supplementary protection
Strength and stability	<ul style="list-style-type: none"> • structural design philosophy (including codes of practice referenced and test reports) • grade of steel (traceability) • section properties • loading • ultimate limit state • serviceability limit state • resistance to overturning • racking resistance • holding down • connections within the system • connections with other building elements • structural integrity • positions and sizes of holes through members
Additional checks where LSF is used in volumetric construction	<ul style="list-style-type: none"> • module-to-module connections (strength as well as accuracy) • module-to-foundation connections • rigidity in transportation • lifting

Where there are various configurations (eg types of claddings), the manufacturer will need to specify which options SCI is to consider in its assessment. Upon satisfactory completion, SCI will approve the manufacturer's system manual and issue a numbered 'system certificate' which includes:

- a detailed description of the system
- details of usage limitations
- information for reference by the designer and LSF project certifier.

Stage 2 — project certification

The design of all primary structural components should be subject to a Stage 2 certification check by an NHBC registered LSF certifier.

The LSF certifier should:

- be listed on NHBC’s list of LSF certifiers
- be a suitably qualified and experienced civil or structural engineer with appropriate professional indemnity insurance
- not be the designer of the LSF or be employed by the same practice
- check supporting details and calculations
- ensure the Stage 1 system certificate is valid and current
- ensure that the proposals are in accordance with the manufacturer’s Stage 1 system certificate (issued by SCI) and this chapter
- provide confirmation that the requirements have been satisfied for the project
- provide the registered builder with the completed and signed project certificate confirming assessment of structural adequacy for each specific project.

The registered builder should ensure that the completed Stage 2 certificate is available on site for inspection by NHBC.

Contact NHBC Business Support via **business-support@nhbc.co.uk**:

- if you require contact details of frame certifiers, or
- to apply to become an LSF certifier.

6.10.4 Structural design of load-bearing floors and walls

LSF floors and walls shall be designed to support and transfer loads safely and without undue movement. Issues to be taken into account include:

- 1) structural floors
- 2) structural walls
- 3) overall stability.

6.10.4.1 Structural floors

Floors should:

- be of the correct type
- be fitted in the specified location
- have suitably sized trimmers around floor openings
- have a typical maximum joist spacing of 600mm, although greater spacings may be applied when designed by an engineer in accordance with Technical Requirement R5 or covered by an SCI system-specific Stage 1 assessment with the project-specific application reviewed and checked by an NHBC registered LSF certifier.

Light steel joists should be fixed to supporting walls by either:

- web cleats
- ‘Z’ or ‘L’ hangers
- a track connection
- direct attachment to wall studs, or
- bearing onto the supporting structure (bearing stiffeners may be required).

Joist support cleats should:

- be of the correct type
- be fitted in the specified location
- use fixings as specified in the design.

Where required, web stiffeners should be properly fitted.

Where joists are fitted directly to light steel wall studs, pre-drilled holes should be correctly aligned before making the final connection.

Fixing holes should not be enlarged, and additional holes should not be cut without prior approval of the designer.

Figure 1: Joist bearing onto structure with stiffener

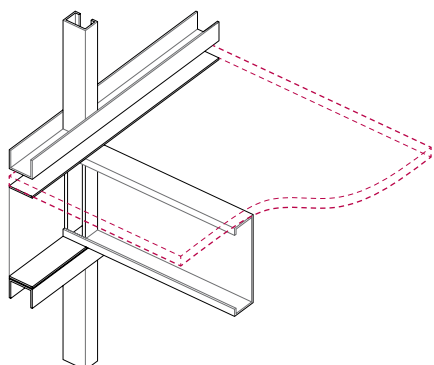

Figure 2: Web cleat connection

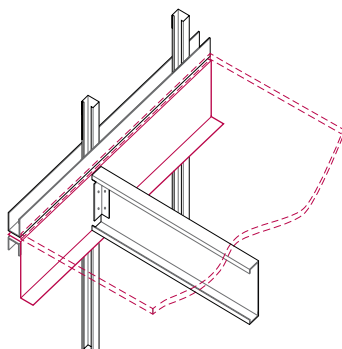
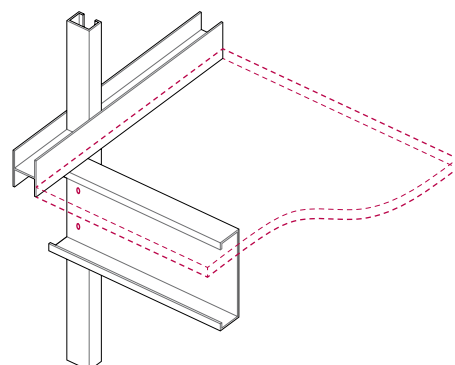

Figure 3: Bolted web-to-web connection



Static criteria for the maximum permissible deflection of a single joist due to:

- imposed load, limited to (span/450)
- dead and imposed loads, limited to the lesser of (span/350) or 15mm.

Dynamic criteria:

- the natural frequency of the floor should not be less than 8Hz for dead load plus 0.2 x imposed load; this can be achieved by limiting the deflection of a single joist to 5mm for the given loading
- the deflection of the floor (ie, a series of joists plus the floor decking) when subject to a 1kN point load should be limited to the values in Table 2.

Table 2: Deflection with point loads of 1kN

Span (m)	Maximum deflection (mm)
3.5	1.7
3.8	1.6
4.2	1.5
4.6	1.4
5.3	1.3
6.2	1.2

The deflection of a single joist is dependent on the:

- overall floor construction
- number of effective joists that are deemed to share the applied 1kN point load (typical values are given in Table 3).

Table 3: Typical values

Floor configuration	Number of effective joists	
	400mm joist centres	600mm joist centres
Chipboard, plywood or oriented strand board	2.5	2.35
Built-up acoustic floor	4	3.5

Light steel ground floor construction

Provision should be made to prevent ground moisture affecting light steel floors. This can be achieved by covering the ground below the floor with either:

- 50mm oversite concrete or 50mm fine aggregate on 1,200 gauge (0.3mm thick) polyethylene membrane laid on 50mm sand blinding, or
- 100mm oversite concrete on a compacted clean, inert hardcore bed. Where necessary, this concrete should be protected against sulfate attack by the use of a lapped polyethylene DPM, not less than 1,200 gauge (0.3mm thick) or 1,000 gauge where assessed in accordance with Technical Requirement R3.

Floors should have a 150mm minimum void below the floor which is ventilated by:

- openings on at least two opposite sides
- 1,500mm² per metre run of external wall or 500mm² per m² of floor area (whichever provides the largest area).

Where there is shrinkable soil, heave can occur. The minimum underfloor void ventilation requirement should be increased as follows:

- high potential — 150mm (300mm total)
- medium potential — 100mm (250mm total)
- low potential — 50mm (200mm total).

See Chapter 4.2 Building near trees for definitions of high, medium and low volume change potential.

For concrete ground floors refer to Chapters 5.1 Substructure and ground-bearing floors and 5.2 Suspended ground floors.

Concrete upper floors

Concrete floors may be used with LSF and may be constructed using either thin precast units or in-situ concrete placed on steel decking. The deflection of simply supported composite floors should be limited to take account of the long-term effects of creep and shrinkage. Composite floors should be appropriately propped until the concrete reaches the required strength and should not be overloaded during construction. Guidance can be found in Section 6.3 of SCI publication P402 Light steel framing in residential construction.

6.10.4.2 Structural walls

The structural design of the building should ensure adequate resistance to loadings including dead loads, imposed loads, wind loads and snow loads, in accordance with:

- BS EN 1991-1-1
- BS EN 1991-1-3
- BS EN 1991-1-4.

Provision of support to heavy attachments such as hung boilers or kitchen units may be required. In such cases, additional light steel plates or noggings can be included to improve strength and use of a suitable sheathing board and/or fixing directly to the steel studs by self-drilling self-tapping screws may also be required.

Further guidance on deflection limits can be found in SCI publications P402 Light steel framing in residential construction and P437 Design of stability systems for light steel framing.

Individual studs should generally:

- be sized to meet structural requirements, allowing for board fixings at joints and construction tolerances
- have a maximum spacing of 600mm
- consider deflection if not designed to carry vertical loading from the primary structure.

Alternative stud arrangements should be agreed with NHBC.

Lintels, including trussed lintels, should be:

- provided to any opening in load-bearing panels where one or more studs is cut or displaced to form the opening, but are not required where an opening falls between studs
- securely fixed to supporting studs to ensure that loads are fully transferred.

At openings, additional studs may be required to provide support or fixing points for wall ties, cladding and wall linings.

Multiple studs should be included to support multiple joists, unless otherwise specified by the designer.

Where panels are diagonally braced with a flat strip, the brace should be fixed to each stud at the intersection to minimise bowing in the bracing member. Alternatively, bracing may be tensioned using alternative methods where included in the scope of the Stage 1 certification.

Appropriate holding-down devices should be provided to resist uplift, where necessary. The anchorage for holding-down devices should have sufficient mass to resist the uplift forces (see Clause 6.10.10).

Where roof trusses sit directly on a top track, the design should consider all loads, such as:

- wind uplift
- lateral support
- vertical loading (assuming that trusses may be offset from studs).

Where included in the design, timber wall plates should be:

- fixed to the head rail of wall panels onto which timber roof trusses bear
- sized (including the head rail) to permit single timber trusses to be positioned at any point between studs.

Allowance for movement, including at openings and penetrations, should:

- prevent load transfer onto services or flues
- consider elastic shortening of the LSF and movement potential of any panels, cladding or boards
- be fully co-ordinated with the whole building design.

Figure 4: Lintel arrangement

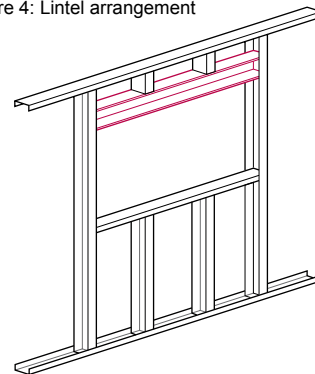

6.10.4.3 Overall stability

Also see: Chapters 7.1 and 7.2

Methods to provide overall stability should either:

- be designed to BS EN 1993-1-1, or
- be tested to BS EN 594.

Wall panels may provide stability using one or more of the following techniques:

- internal bracing
- external sheathing board in accordance with Clause 6.10.20
- crossed flat bracing
- rigid frame action.

Internal lining boards can be used where demonstrated to be suitable for the purpose.

6.10.5 Structural design of infill walls

Infill walls shall be designed to support and transfer loads to the structure safely and without undue distortion or movement.

Infill panels should be designed to resist the expected wind loads, any loads transferred by the cladding system, and those imposed by windows and doors within the panels. Load concentrations resulting from the presence of openings should also be considered. The design should be in accordance with BS EN 1993-1-3. Additional information can be found in SCI publication ED017 Design and installation of light steel external wall systems.

6.10.6 Roofs

Roofs supported by LSF constructions shall be designed to support the roof coverings and transfer loads safely and without undue movement.

Connections between LSF walls and timber or LSF pitched roofs require careful consideration in the design.

LSF pitched or flat roofs should only be used in warm roof or hybrid construction ie, with insulation over rafters (or joists in flat roofs).

Condensation risk should be considered in accordance with BS 5250.

6.10.7 Steel and fixings

Steel and fixings shall be suitable for the intended use. Issues to be taken into account include:

- | | |
|---------------------------------|----------------------------|
| 1) steel grade | 3) connections and fixings |
| 2) protection against corrosion | 4) holes and notches. |

6.10.7.1 Steel grade

Steel should be in accordance with BS EN 10346 and of any of the following grades:

- S280
- S320
- S350
- S390
- S420
- S450.

6.10.7.2 Protection against corrosion

All steel should be pre-galvanized in accordance with BS EN 10346 (minimum 275g/m² zinc coating (Z) or 150g/m² aluminium-zinc alloy coating (AZ)). Structural steel members should not be altered without the approval of the designer. Welded zones should be cleaned and treated with a zinc-rich paint to prevent corrosion.

Where the LSF floor is to be located at 150mm or more above the external ground level, the junction between the ground floor joists and their support should be designed to maintain the durability of the floor. Light steel floor joists and ring beams in such floors should be galvanized to 450g/m².

Alternatively, they can be galvanized to 275g/m² with additional protection of a two-coat bitumen-based coating to BS 1070, BS 3416 or BS 6949, or have a two-coat liquid asphaltic composition applied. Ring beams to ground floors should be totally protected, and joists protected for a minimum of 300mm adjacent to an external wall support or ring beam.

Where steel is used less than 150mm above ground level the guidance in Clause 6.10.16 should be considered.

6.10.7.3 Connections and fixings

Where two metals are to be joined, they should either be:

- compatible and not cause bimetallic corrosion, or
- isolated from each other.

Connections should be:

- properly installed
- justified in accordance with BS EN 1993-1-3 or a test method acceptable to NHBC.
- securely made by clinching, crimping or by one of the methods detailed in Table 4

Table 4: Types of connections

Type of connection	Relevant standard
Cleats	BS EN 1993-1-1
Countersunk bolts (tightened to the correct torque)	BS 4933
Hot-dip galvanized fasteners	BS EN ISO 10684
Rivets, including self-piercing rivets	Manufacturer's recommendations
Screws	BS EN ISO 10666 BS EN ISO 15480 BS EN ISO 15481 BS EN ISO 15482 BS EN ISO 15483 (also see BS EN ISO 4042)
Welded connections	BS EN 1011 and BS EN 1090
Zinc-plated bolts	BS 7371-3

Holding-down devices

Holding-down devices should be suitable for the environment they will be exposed to, and manufactured from:

- mild steel with zinc coating to BS EN ISO 1461
- stainless steel to BS EN 10095 (suitable for most environments).

6.10.7.4 Holes and notches

Joists and studs should not be altered without the approval of the steel frame designer, and the drilling, cutting or punching through of members shall only be undertaken to an engineer's design in accordance with Technical Requirement R5.

To prevent damage to services, holes and penetrations should be fitted with grommets or swaged under factory conditions.

End notching of light steel joists may be required for the interconnection of trimming joists and should be in accordance with the design. Notches elsewhere in the span are not acceptable.

Also see Clause 6.10.22.

Figure 5: Holes and notches

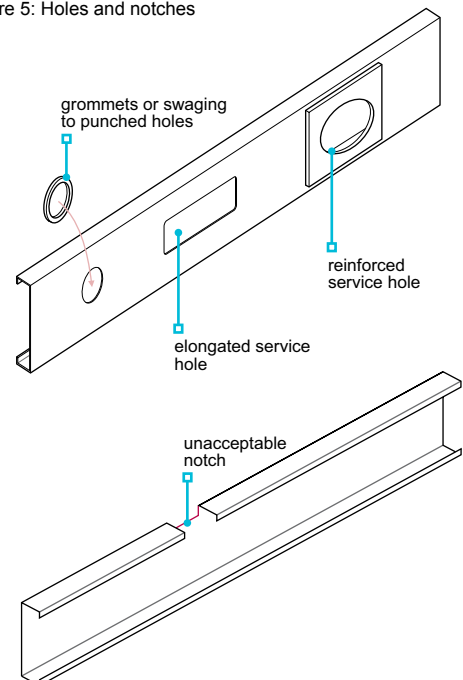

6.10.8 Detailing of steel joists

Steel joists, fixings and connections shall be suitably detailed and provide satisfactory performance. Issues to be taken into account include:

1) installation details

2) prevention of roll.

6.10.8.1 Installation details

Joists or floor beams should be:

- spaced as shown in the design
- accurately cut to length in accordance with the manufacturer's recommendations to ensure a tight fit
- joined with the correct type, size and number of fixings.

Where light steel joists are supported by steel joists, cleats or web stiffeners should be used in accordance with the design.

Joists may be doubled up to support partitions or to form trimmers.

Continuous joists on load-bearing intermediate walls should be reinforced as required by the design.

Figure 6: Web stiffeners for continuous joists over load-bearing intermediate wall

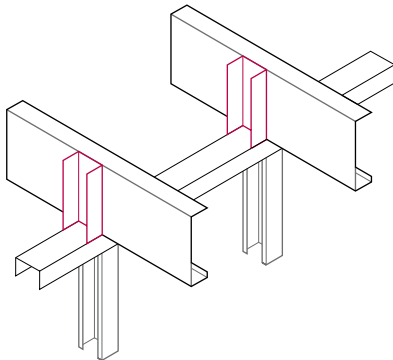
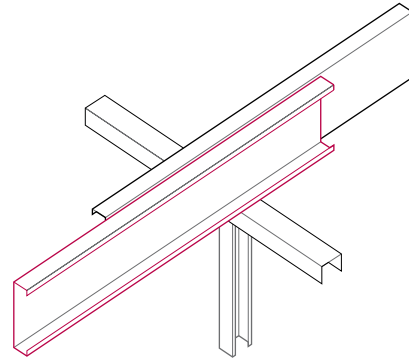

Figure 7: Joists overlapping on load-bearing intermediate wall



Where joists overlap on load-bearing intermediate walls, they should be fixed together with bolts or screws. This is to prevent the floor decking being pushed up, or the ceiling being cracked, when the cantilevered part of the joist moves upwards.

6.10.8.2 Prevention of roll

Bridging and blocking should be provided in accordance with the design to prevent roll.

Floors constructed using joists with an asymmetric web, eg of C or Sigma profile, can cause the floor to roll. To avoid roll, unless otherwise specified in the design, one of the following alternatives should be used where the span exceeds 3.5m for C joists or 4.2m for Sigma joists:

- a continuous line, or lines, of proprietary steel herringbone struts provided between the joists; the pairs of struts should have a physical gap between them so that they do not rub against each other at the cross-over point and create noise
- solid blocking provided to every alternate pair of joists with ties between them as shown
- joists alternately reversed and tied together in pairs
- joists alternately reversed and continuous ties (eg resilient bar) fixed to the joist flanges.

Where joists bear onto steelwork or are supported by cleats, blocking is not necessary adjacent to the supports.

Figure 8: Floor bracing examples

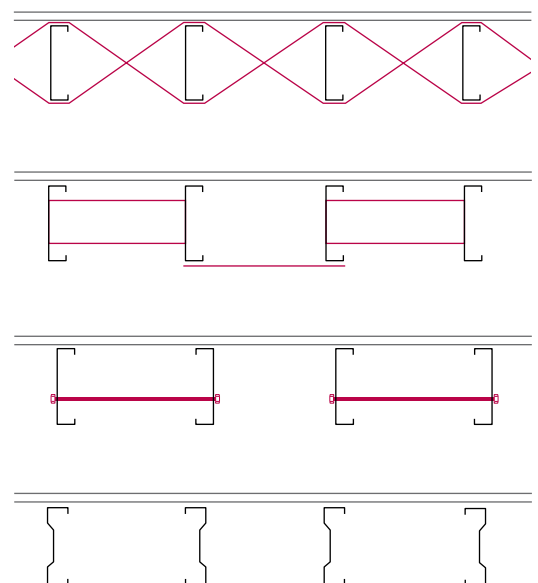

6.10.9 Restraint

Restraint strapping shall be provided in accordance with the design.

Where external walls, not constructed from LSF, are to be stabilised by a connection to the floor, straps may be required. Straps will generally be fixed to the web of the joist, to suit the masonry courses.

Where joists run parallel to the wall, straps should be supported on noggings fixed between the joists. Straps should be placed at a maximum of 2m apart and carried over three joists. Packing should be provided between the wall and the first joist.

Straps should be fixed with suitable bolts, screws or rivets and should bear on the centre of bricks or blocks, not across mortar joints.

6.10.10 Construction of load-bearing walls and external infill walls

Construction of load-bearing walls and external infill walls shall ensure adequate stability. Issues to be taken into account include:

- 1) preparation
- 2) anchoring
- 3) accommodation of deflection.

6.10.10.1 Preparation

The following should be in accordance with the design:

- the setting out of the structure onto which the LSF is to be erected
- the transfer of loads from the LSF.

The supporting structure may have local deviations in level along its length, and packing will be required to achieve the required tolerances and to provide for effective load transfer.

Concrete kickers should be carefully formed, ensuring that the concrete is adequately compacted and the top surface is suitably flat and level.

Figure 9: Floor edges

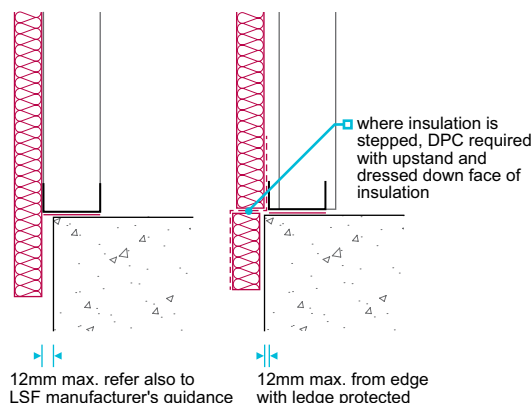

Table 5: Acceptable methods of packing under frames

Gap under base rail	Acceptable packing
Less than 10mm	Provide shims under each stud position
10-20mm	Provide shims under each stud position, and grout under the whole length of the base rail with cement: sand mortar
More than 20mm	Obtain advice from the frame designer/manufacturer Remedial work to the substructure may be required before erection commences

Shims should be of pre-galvanized steel (the galvanized coating being at least equivalent to that of the member/s being packed) or other suitable material ie, not timber or plastic.

Wall frames should be checked to ensure that they are dimensionally accurate before erection commences.

LSF should be correctly positioned, square and plumb, and within the following tolerances:

- the vertical position of members should be within $\pm 5\text{mm}$ per storey relative to the base
- the horizontal position of base rails should not vary in alignment by more than 5mm in 10m.

Figure 10: Correct positioning

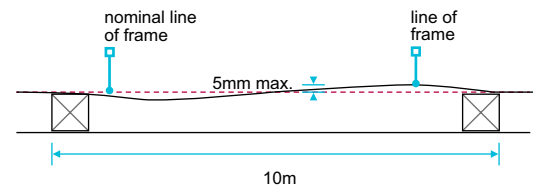

6.10.10.2 Anchoring

The frame should be anchored to resist both lateral movement and uplift in accordance with the design, including bolt-down brackets where required.

Figure 11: Strap anchor example

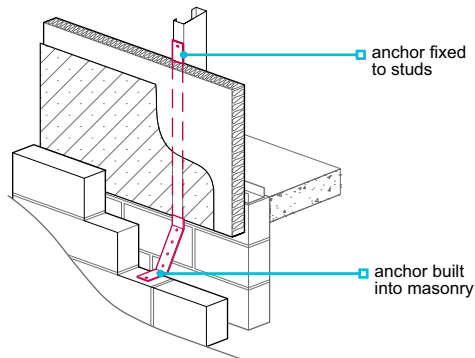
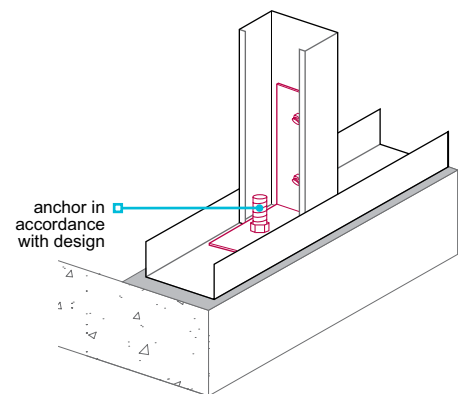

Figure 12: Bolt-down anchor example



Anchoring should ensure:

- that appropriate edge details are provided and minimum edge distances specified by the fixing supplier are maintained, to avoid spalling of masonry or concrete
- where fixings are into masonry, they are into solid concrete blocks with a minimum crushing strength of 7.3N/mm^2 and positioned to receive fixings.

Where the design incorporates gas membranes (methane or radon), fixings should not puncture them, but where this is unavoidable, the penetration should be sealed.

6.10.10.3 Accommodation of deflection

Infill walls should accommodate anticipated deflection within the primary frame in accordance with the structural design.

6.10.11 Interfaces with staircases

Also see: Chapter 6.4

Floors and walls shall be designed to accommodate installation of any staircases without compromising performance.

Wall linings should be continuous behind the string of staircases.

Fixing connections should be co-ordinated to ensure fire protection continuity and structural adequacy.

6.10.12 Fixing floor decking and ceilings

Floor decking and ceilings shall be adequately fixed using a material of adequate strength and moisture resistance.

Joist spacing and decking thickness should be compatible. Material standards and minimum board thicknesses for domestic loads (imposed load of 1.5kN/m²) are shown in Table 6.

Table 6: Joist spacing and decking type

Material	Standard	Minimum thickness of decking (mm)	
		400mm joist centres	600mm joist centres
Chipboard	BS EN 312 moisture-resistant type P5	18	22
Plywood	BS EN 636	15	18
Oriented strand board type OSB3	BS EN 300	15	18
Other materials	In accordance with Technical Requirement R3		

In England and Wales, the thicknesses listed above may not achieve the 15kg/m² mass required to meet sound insulation requirements.

Flooring should be fixed at maximum 300mm centres using self-tapping screws or fixings recommended by the LSF manufacturer and in accordance with Chapter 6.4 Timber and concrete upper floors.

Plasterboard should be fixed in accordance with Chapter 9.2 Wall and ceiling finishes, using self-drilling, self-tapping screws.

6.10.13 Other design issues

The home shall be designed to adequately address all critical performance issues.

The designer should ensure that all critical performance issues listed in Table 7 are appropriately addressed.

Table 7: Critical performance issues requiring the designer's consideration

Topic	Description
Behaviour in relation to fire	<ul style="list-style-type: none"> • compliance with relevant Building Regulations • internal linings • fire stops and cavity barriers • penetrations
Acoustic performance	<ul style="list-style-type: none"> • compliance with relevant Building Regulations
Moisture control, including thermal performance, condensation risk and water ingress	<ul style="list-style-type: none"> • type, thickness and location of insulation material • protection from water ingress at low levels • condensation risk analysis and management of water vapour in the structure
Wall construction	<ul style="list-style-type: none"> • acceptable claddings (see Chapter 6.9 Curtain walling and cladding) • provision of cavity • type of wall ties • sheathing • attachments (eg hung boilers or kitchen units)
Balconies, terraces and parapets	<ul style="list-style-type: none"> • specific design considerations: structural design, durability, weathertightness

Guidance for some of the performance issues listed in Table 7 may be included in the Stage 1 certificate.

6.10.14 Behaviour in relation to fire

LSF walls and floors shall be in accordance with relevant Building Regulations.

Guidance within supporting documents to the relevant Building Regulations should be fully considered in the design and construction of LSF walls, floors and roofs.

Detailing and specification of components should be in accordance with the steel frame manufacturer's recommendations and/or guidance from SCI (see guidance in P424 Light steel framing in fire) and supported with representative test evidence to appropriate standards such as BS 476-21 or BS EN 1365-1 for load-bearing walls, BS 476-22 or BS EN 1364-1 for infill walls and BS EN 1365-2 for floors.

The performance of specific details should be taken into account, including:

- fire protection to the structure around openings
- detailing around service penetrations
- detailing of cavity barriers, including moisture protection to the barrier
- compartmentation including interfaces with fire doors.

6.10.15 Acoustic performance

LSF walls and floors shall have adequate resistance to the passage of sound.

Internal walls and floors should be in accordance with relevant Building Regulations.

Separating walls

Separating walls should be in accordance with the design. Care should be taken to avoid gaps:

- between mineral wool quilt or batts
- between cavity barriers
- between internal lining board layers
- around openings for services.

Separating floors

The floating part of a floor should be separated from the main structure and surrounding walls by a resilient layer. Where boards are laid loose over insulation without battens, joints should be glued.

6.10.16 Moisture control

The structure shall be adequately protected from the effects of moisture. Details for LSF at low level shall fully consider the durability of materials, protection of the building from moisture ingress and thermal bridging. Issues to be taken into account include:

- 1) cavities in external walls
- 2) protection of steel at low level
- 3) DPCs, DPMs and cavity trays.

6.10.16.1 Cavities in external walls

A clear cavity in accordance with Table 8 should be provided between the cladding and insulation.

Table 8: Minimum cavity widths

Cladding	Cavity width
Masonry	50mm
Render on board background	25mm
Vertical tile hanging ⁽¹⁾ where a breather membrane is provided and fixed to the sheathing	Dependent on batten support layout and spacing ⁽¹⁾
Other cladding ⁽¹⁾	15mm

Note

1. See Chapter 6.9 Curtain walling and cladding.

The cavity should:

- extend at least 150mm below the DPC
- be kept clear to allow drainage
- be provided with weepholes or other suitable means of drainage.

6.10.16.2 Protection of steel at low level

The base rail of LSF should be kept a minimum of 150mm above the external ground level (or waterproofing layer of a flat roof, balcony or terrace) and cavity fill. In such cases, the LSF may be protected against corrosion in accordance with Clause 6.10.7.

Locally raised ground levels (up to the internal floor finish) to less than 15% of the external perimeter (of an individual building, eg row of terraced homes, apartment blocks and detached garages, measured on plan) to accommodate level thresholds can be accepted. The cavity should be kept clear and allow drainage. Wall insulation should overlap the base rail by a minimum of 150mm.

Figure 13: Ground level interface

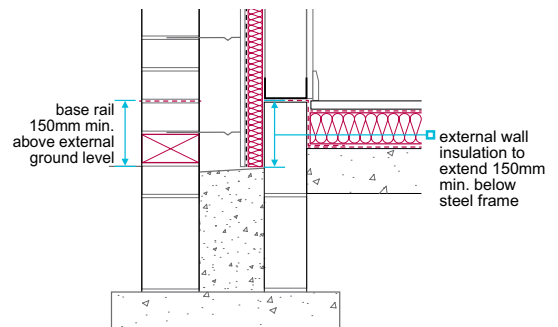

Alternatively, where the base rail or lowest steel is less than 150mm above ground level (or waterproofing layer of a flat roof, balcony or terrace), the design should consider the following:

- factory-applied protection to the steel frame to achieve a design life of 60 years. This may be LSF:
 - Galvanized to 600g/m², or
 - Galvanized to 275g/m² with the addition of two coats of heavy duty bituminous paint, 200µm total thickness
- sheathing, or backing boards to waterproofing, used below 150mm, should be service class 3 in accordance with BS EN 13986
- drainage of the cavity (ground conditions should be considered where the cavity discharges below ground level)
- insulation to limit thermal bridging and interstitial condensation. NHBC may ask for thermal modelling of the junction to demonstrate that these issues have been sufficiently limited.

Where levels are raised above the base rail or lowest steel:

- local areas of LSF walls (less than 15% of the external perimeter) retaining up to a maximum of 600mm of ground can be acceptable, subject to appropriate waterproofing design
- in addition, where more than 15% of the external perimeter has ground levels above the internal floor finish (up to a maximum of 600mm), the structure should be designed by an engineer in accordance with Technical Requirement R5.

Waterproofing should be designed by a waterproofing design specialist and be in accordance with Chapter 5.4 Waterproofing of basements and other below ground structures.

The manufacturer of the waterproofing system should confirm compatibility between the waterproofing and sheathing board, which should be supported by test evidence.

6.10.16.3 DPCs, DPMs and cavity trays

DPCs, DPMs and cavity trays should:

- be provided at openings to prevent rain penetration
- be installed underneath the full width of the base rail and lap with the DPM where present.
- materials assessed in accordance with Technical Requirement R3.

Materials acceptable for use as DPCs include:

- BS 6515 polyethylene
- BS 6398 bitumen

6.10.17 Insulation

Insulation shall be correctly installed, be of a suitable material and thickness to comply with relevant Building Regulations and reduce the risk of interstitial condensation.

Insulation should:

- be inert, durable, rot and vermin proof, and should not be adversely affected by moisture or vapour
- cover the whole external face of the wall and be complete within the frame
- extend 150mm below the base rail to minimise thermal bridging and maintain a warm frame
- be tightly butted with joints of rigid board insulation taped, where required by the design.

Foil-faced insulation boards with an integral facing on one side only should be fixed with the foil face on the cavity side.

Table 9: Acceptable insulation materials

Material	Relevant standard
Mineral wool	BS EN 13162
Flame retardant (FR) grade expanded polystyrene	BS EN 13163
FR grade extruded polystyrene	BS EN 13164
Rigid polyurethane foam and polyisocyanurate	BS EN 13165
Phenolic foam	BS EN 13166
Cellular glass	BS EN 13167
Other insulation materials	Technical Requirement R3

Account should be taken of Accredited Construction Details where applicable.

Reference should be made to BRE document BR 135 Fire performance of external thermal insulation for walls of multi-storey buildings when specifying the type of insulation system to be installed.

6.10.18 Air and vapour control layers

Air and vapour control layers (AVCLs) shall restrict the passage of vapour from within the home to the steel frame and be correctly installed.

An AVCL should be provided, unless a condensation risk analysis shows it is not necessary. An analysis in accordance with BS EN ISO 13788 (Glaser method), using the following boundary conditions, will generally be acceptable:

- >60% internal RH
- at 21°C internally
- at -2°C externally.

Split layers of AVCL-type material should be avoided, except where condensation risk analysis shows it to be acceptable.

Where they are provided, AVCLs should be:

- 500g polyethylene sheet, vapour control plasterboard, or material assessed in accordance with Technical Requirement R3
- fixed on the warm side of the wall insulation and frame
- in accordance with the design
- placed to cover the external wall, including base rails, head rails, studs, lintels and window reveals
- overlapping the base rail
- fully sealed and punctures made good.

Where polyethylene sheet is used:

- each joint in the AVCL should be located on studs or noggings and lapped by a minimum of 100mm
- double-sided tape or adhesive should be used as a temporary fixing before the wall board is fixed.

Where vapour control plasterboard is used:

- joints between sheets should be positioned on studs or noggings
- care should be taken not to displace the vapour control material when cutting vapour control plasterboard.

6.10.19 Breather membranes

Breather membranes shall be capable of allowing vapour to pass into the cavity, and provided to protect the sheathing and frame from external moisture.

Breather membranes should be:

- vapour resistant to less than 0.6MNs/g (0.12Sd) when tested in accordance with BS EN ISO 12572 using the set of conditions C and using five test specimens
- capable of resisting water penetration
- self-extinguishing
- durable
- installed so that each joint is protected and moisture drains outwards
- lapped to a minimum of 100mm at horizontal joints and a minimum of 150mm at vertical joints
- at least Class W2 to BS EN 13859-2 with no water leakage during testing. In areas of very severe exposure (see Clause 6.1.6 for classification of exposure zones) or where liquid water penetration of the cladding is anticipated, for example open-jointed cladding, Class W1 should be used. When open-jointed claddings are used or the membrane is likely to be left exposed during construction for a duration longer than normally to be expected (also see the membrane manufacturers' recommendations on exposure times), performance should be based on artificial aged behaviour in accordance with BS EN 13859-2. Where a vented and ventilated cavity with full rainscreen and no gaps, for example masonry or rendered board claddings, are used, performance should be based on artificial aged behaviour in accordance with BS EN 13111.

Breathable membranes should be used to protect sheathing board and insulation. Breather membranes may be omitted where water-resistant insulation boards with taped joints are used. Tape should be of a type recommended by the insulation manufacturer, breathable to allow water vapour to move freely and resist water penetration. Suitable taping should be applied at the lintel interfaces and other penetrations to direct water outside.

6.10.20 Cladding, lining and sheathing boards

Cladding panels, lining and sheathing boards shall be suitable for their intended purpose. Issues to be taken into account include:

- | | |
|----------------------|----------------------------|
| 1) external cladding | 3) internal lining boards. |
| 2) sheathing | |

6.10.20.1 External cladding

The design and construction of the external walls should fully consider:

- cavity drainage
- differential movement
- restraint
- fire resistance.

In external walls, a clear cavity should be provided between the external insulation and the cladding. The cavity should:

- be drained
- have cavity trays and weepholes installed where the cavity is not fully maintained, eg at cavity barriers
- be kept clean, free of obstructions and capable of draining freely
- have drainage at its base, equivalent to 500mm²/m run, eg for masonry, one open perpend every 1.5m
- have drainage openings placed to prevent the ingress of rain.

Masonry cladding should:

- be constructed in accordance with Chapter 6.1 External masonry walls
- not be supported by the LSF walls unless designed in accordance with Technical Requirement R5
- be tied to the LSF walls with flexible wall ties fixed through to the studs
- include movement joints as appropriate (eg a 1mm gap per continuous metre of vertical clay masonry should be provided at openings and soffits) to allow for differential movement due to thermal expansion, shrinkage (in concrete masonry) and moisture expansion (in clay) in accordance with PD 6697. The brick/block manufacturer's advice should be sought on the level of movement to be expected.

Figure 14: Allowing for differential movement

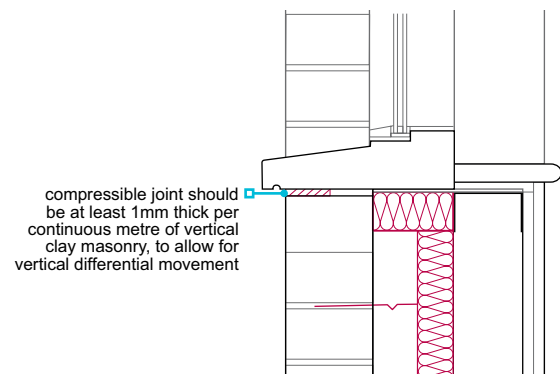

Lightweight cladding should be:

- in accordance with Chapter 6.9 Curtain walling and cladding
- compatible with the LSF system construction
- supported by systems assessed in accordance with Technical Requirement R3 which ensure that cladding design loads are effectively transferred to the building structure.

6.10.20.2 Sheathing

Sheathing boards should be:

- of a suitable strength and quality
- compatible with the steel frame
- attached using suitable quality fixings.

Sheathing boards contribute to meeting many of the critical performance issues described in Table 7 and cannot be easily replaced, so they should be specified in accordance with the design life of the building.

Sheathing boards should be appropriate for the exposure of the building and suitable for use in humid conditions.

Table 10: Requirements for sheathing board materials

Material	Relevant standards	Minimum thickness (mm)
Cement bonded particle board	BS EN 13986 BS EN 634 BS EN 12467	By design
Oriented strand board (OSB3 required)	BS EN 300	8.0
Plywood	BS EN 13986 BS EN 636	5.5
Proprietary materials	Technical Requirement R3	Technical Requirement R3

Fixings used to apply sheathing boards should be selected in accordance with the board manufacturer's instructions and be suitably specified for strength and long-term durability in the anticipated exposure condition.

Sheathing boards should be adequately protected from weather during construction. This can be done through a combination of:

- the use of water-resistant boards with accredited proof of performance in accordance with Technical Requirement R3
- the use of sealed jointed water-resistant insulation to reduce water penetration
- the application of a breathable membrane to the sheathing board
- sequencing construction to minimise daily exposure with fully waterproof temporary coverings overnight and during inclement weather.

For all sheathing board types, junctions between adjacent boards, and at interfaces with other building elements, should be sealed and/or taped in accordance with the manufacturer's recommendations.

A breather membrane should be used to provide protection to the building during and after construction in areas of very severe exposure to wind-driven rain.

6.10.20.3 Internal lining boards

Internal lining boards should be:

- fixed in accordance with the design and the manufacturer's recommendations
- attached to light steel studs using self-drilling, self-tapping screws at a maximum of 300mm centres.

In addition to the general guidance for internal lining boards, plasterboard should:

- be shown to provide adequate fire resistance where required
- comply with BS EN 520 and be in accordance with Chapter 9.2 Wall and ceiling finishes
- be a minimum of 9.5mm for stud spacing up to 450mm
- be a minimum of 12.5mm for stud spacing up to 600mm.

6.10.21 Wall ties

Wall ties shall be suitable to connect the steel frame to the cladding.

Generally, wall ties should be:

- in accordance with BS 845-1
- fixed to the studs and not the sheathing
- inclined away from the LSF
- austenitic stainless steel and of a type which accommodates the differential movement between the LSF and the cladding, or assessed in accordance with Technical Requirement R3.

Figure 15: Providing wall ties

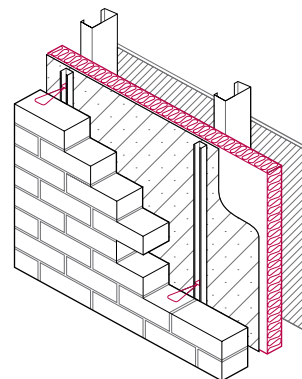

Wall ties for masonry cladding should be according to the design and:

- installed at a minimum density of 3.7 ties/m², eg spaced at a maximum of 600mm horizontally and 450mm vertically (except where alternative densities have been demonstrated by building-specific calculation and accepted under the Stage 2 certificate)
- spaced at jambs of openings, a maximum of 300mm vertically within 225mm of the masonry reveal (additional studs may be needed to achieve this)
- kept clean and free from mortar droppings.

6.10.22 Services

Services shall be adequately protected from damage.

Service mains and service outlets should be:

- designed to ensure the fire resistance of walls and floors is not impaired
- designed to ensure that the required sound insulation of walls and floors is maintained
- installed in accordance with the design
- on the warm side of the insulation.

Light steel joists or studs should not be notched to accommodate services. Holing of structural light steel members should be carried out in accordance with this chapter and the manufacturer's recommendations. On-site hole cutting should be avoided, as badly cut edges can have an adverse effect on the durability of the frame and may cause damage to pipes and cables.

Where on-site adaptation of the frame is unavoidable, it should be undertaken by the manufacturer, with prior notification to NHBC, and completed in line with the steel frame designer's remedial details with all cut edges treated and badly cut edges avoided. Significant adaptations should be overseen by the design engineer.

Grommets should be used around the edge of service holes to protect electrical cables and reduce the risk of bimetallic corrosion between the LSF and copper pipes. Swaged holes for electric cables and plastic piping do not require grommets.

In Scotland, services are not permitted within:

- framed separating walls
- separating wall cavities.

6.10.23 Further information

- *The Steel Construction Institute (SCI) publications, Silwood Park, Ascot, Berkshire, SL5 7QN*
SCI publications:
 - *Building design using cold formed steel sections: construction detailing and practice (P165)*
 - *Modular construction using light steel framing: design of residential buildings (P302)*
 - *Light steel framing in residential construction (P402)*
 - *Design and installation of light steel external wall systems (ED017)*
 - *Design of stability systems for light steel framing (P437)*

Technical Disclaimer

The NHBC Standards are produced by NHBC as guidance solely for our builder customers as to how to interpret the technical requirements in relation to the warranty cover provided by NHBC under its Buildmark, Buildmark Choice, Buildmark Link, Buildmark Solo, Buildmark Connect or any similar product from time to time. It has not been created or intended for distribution or use outside of that purpose. The information contained in the NHBC Standards do not constitute advice and is not to be relied upon by any third party. Nothing in the NHBC Standards is intended to, nor should it be taken to, create any legal or contractual relationship. Any third party who chooses to rely upon the information contained in the NHBC Standards shall do so entirely at their own risk and NHBC accepts no duty of care or liability, however caused, in connection with its use or reliance by any third party.