



## Chapter

# 9.1



## A consistent approach to finishes

This chapter gives guidance on meeting the Technical Requirements for finishes in new homes.

9.1.1	Compliance	01
9.1.2	External walls	01
9.1.3	Internal walls and ceilings	04
9.1.4	Doors and windows	05
9.1.5	Floors	06
9.1.6	Glazing	07
9.1.7	Ceramic, concrete, terrazzo and similar tile finishes	07
9.1.8	Fitted furniture	07
9.1.9	Joint sealants	08
9.1.10	Paint finishes	08
9.1.11	Sanitary ware	08
9.1.12	Other surfaces and finishes	08
9.1.13	Pitched roof coverings	09
9.1.14	Garages	09
9.1.15	External works	09
9.1.16	Further information	09

For figure reference tables, please go to the end of each chapter.



### 9.1.1 Compliance

Also see: Chapter 2.1

#### Finishes shall comply with the Technical Requirements.

Finishes that comply with the guidance in this chapter will generally be acceptable.

This guidance:

- is intended to apply when the home is substantially complete and ready for NHBC pre-handover inspection
- will be used by NHBC both during the construction process and when conducting resolutions under section 2 of the Buildmark insurance cover
- should be considered in conjunction with relevant performance standards and guidance contained elsewhere within NHBC Standards
- uses tolerances and finishes considered to be appropriate for the house-building industry and takes precedence over other recommendations
- is not intended to deal with every situation which may arise, and discretion should be exercised.

Some elements may be subject to the effects of normal thermal or drying movement, and this may occur both before and after completion.

Some materials are not uniform and are not intended to be; this includes reclaimed materials. Some colour and texture variation is inevitable; this is often used as an aesthetic feature and should be recognised in appropriate tolerances or considered separately. Acceptability of finished appearances will be in the opinion of NHBC.

The nature and extent of work necessary to remedy minor variations from the tolerances and finishes given should be proportionate and appropriate to the circumstances: for example, how readily visible or extensive the affected part of the construction is.

### 9.1.2 External walls

Also see: Chapter 6.11

#### External walls shall have an acceptable finished appearance. Issues to be taken into account include:

- |                        |                         |
|------------------------|-------------------------|
| a) fair faced masonry  | e) brick slip cladding  |
| b) render              | f) timber cladding      |
| c) curtain walling     | g) tile hanging         |
| d) rainscreen cladding | h) cast stone elements. |

Tolerances and appearance should be considered:

- for the entire wall (eg panels and interfaces), and not for the individual elements of the construction, such as individual bricks, individual bed joints, or design features and details (eg quoins, soldier courses and plinths)
- in daylight, and from a minimum distance of 10m.

#### Fair faced masonry

Fair faced masonry should:

- be reasonably uniform in texture, finish and colour, including mortar
- not have excessive colour banding
- not have significant cracks in the facing bricks or other damage, such as chips and marks greater than 15mm in diameter.

Where a fair faced finish can only be achieved on one side (such as half brick walls), the other faces should be left neat and tidy.

Also note:

- some mortar blemishes will occur on individual masonry units
- some variation will occur in the texture, finish and colour of mortar, in individual masonry units and generally over the wall
- efflorescence occurs naturally in some types of masonry. It is not harmful and generally disappears over time
- some brick products have features or marks which may be in excess of 15mm in diameter
- some minor shrinkage cracking may occur between masonry units (bricks and blocks) and mortar joints.

Fair faced masonry should meet the following tolerances:

- adequately straight on plan, with a  $\pm 8\text{mm}$  maximum deviation in any length of wall up to 5m
- adequately straight in section, with a tolerance of  $\pm 8\text{mm}$  per storey height (up to 3m)
- a maximum of 8mm from plumb in any storey up to 3m. Taller walls should be a maximum of 8mm from plumb per storey and 12mm in total
- a maximum deviation of 4mm over 1m at external reveals.

Figure 1: Straightness in plan for fair faced masonry

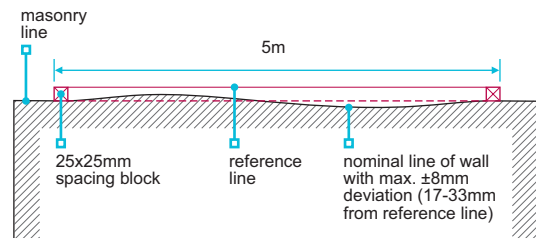

straightness in plan

Example:  
Using 25mm wide spacing blocks, the masonry line should be 17-33mm from the reference line.

Spacing block dimensions are a guide, and final dimensions should ensure the reference line is kept clear of the wall face.

Figure 2: Straightness in section for fair faced masonry

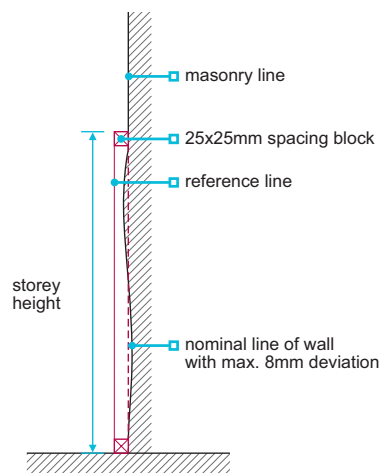

straight in section

Example:  
Using 25mm wide spacing blocks, the masonry line should be 17-33mm from the reference line.

Spacing block dimensions are a guide, and final dimensions should ensure the reference line is kept clear of the wall face.

Figure 3: Plumb in section for fair faced masonry

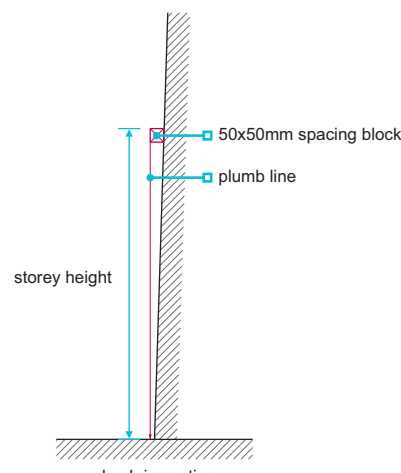

plumb in section

Example:  
Using 50mm wide spacing blocks, the plumb bob should be 42-58mm from the wall, measured at between 2.5-3m from the spacing block.

Note:  
Spacing block dimensions are a guide, and final dimensions should ensure the plumb line is kept clear of the wall face.

Figure 4: Straightness at reveals for fair faced masonry

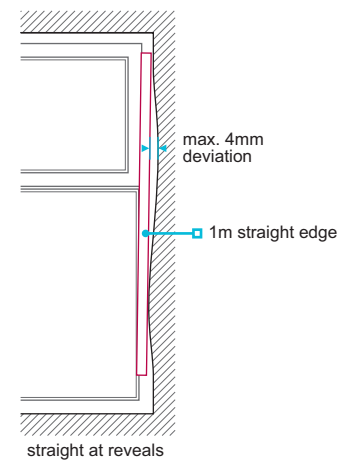

straight at reveals

Bed joints should be reasonably straight, measured along the top of a given row of bricks, with:

- a maximum deviation from straightness of  $\pm 8\text{mm}$  in any 5m section of wall.

The thickness of an individual bed joint should not vary from the average of the next eight successive joints by a maximum of  $\pm 1.5\text{mm}$ .

Figure 5: Straightness of bed joints in fair faced masonry

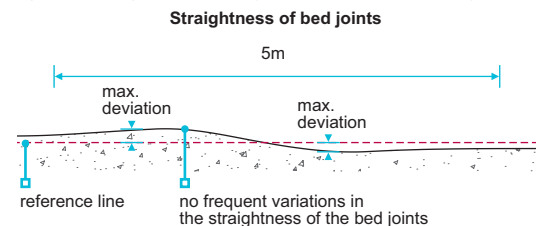

Straightness of bed joints

### Example of how to determine if bed joint thickness is acceptable

Measure and add 8 successive bed joints and divide by 8 to determine the average size:

$$11+10+12+10+11+9+11+10 = 84$$

$$\text{Divide by } 8 = 10.5\text{mm}$$

Therefore, the acceptable range of the bed joint below the 8 measured bed joints is 9-12mm.

Perpend joints should not cumulatively displace in the same direction for more than 5 joints. The centre line of any perpend joint should generally be within  $\pm 15\text{mm}$  of the centre line of the next 5 successive perpend joints.

Also note:

- to achieve setting out, perp joints in masonry panels between openings may be offset with the perp joints in the panels above and below. The joints within the panel should not cumulatively displace.

### Render

Render should:

- be reasonably consistent in texture, finish and colour
- be flat, within a maximum  $\pm 4\text{mm}$  vertical and horizontal deviation in 5m
- be free from crazing (a set of hairline cracks, generally less than 1mm in depth and no more than 0.2mm wide).

Also note:

- there may be some colour variation in appearance due to differences in suction of the background and orientation of the wall
- daywork joints, patching and other repairs may be visible but should not be unduly obtrusive
- some localised hairline cracking is likely to occur in both traditional render and proprietary render systems. Such cracking and crazing should not impair the performance of the home
- areas of render in close proximity to features (eg bell casts) are excluded from the tolerance
- flatness is measured in a similar way to straightness and plumb of masonry.

Figure 6: Straightness in section for render

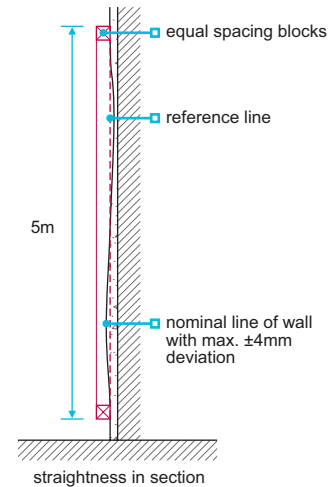

Example:  
Using 25mm wide spacing blocks, the masonry line should be 21-29mm from the reference line.  
Spacing block dimensions are a guide, and final dimensions should ensure the plumb line is kept clear of the wall face.

### Curtain walling

Curtain walling should be within:

- reasonable tolerances and appearance for the materials
- a maximum deviation of  $\pm 2\text{mm}$  in any storey height or structural bay width, and  $\pm 5\text{mm}$  overall, unless otherwise specified in the design.

### Rainscreen cladding

Rainscreen cladding should be within:

- reasonable tolerances and appearance for the materials
- a maximum deviation of  $\pm 3\text{mm}$  in any storey height or structural bay width, unless otherwise specified in the design.

### Brick slip cladding

Brick slip cladding should meet the same tolerances as fair faced masonry.

### Timber cladding

Variation in colour may occur in uncoated timber exposed to the weather, and the rate and extent may vary.

Also note:

- the effects of normal weathering over time may cause uncoated timber to develop a silver/grey colour
- variations in the weathering of uncoated timber cladding may occur as a result of building features such as projecting sills and roof overhangs.

### Tile hanging

Panels should be reasonably uniform in appearance, particularly at abutments. Tiles should not have significant variations in texture, finish and colour. See Clause 9.1.13.

### Cast stone elements

Cast stone should be reasonably uniform in both colour and texture.

Also note:

- efflorescence, fungal growth and colour variation may occur due to orientation, shading and pollution
- surface abrasions and chips should be repaired in accordance with the manufacturer's recommendations.

### 9.1.3 Internal walls and ceilings

Internal walls and ceilings shall be built to appropriate tolerances and have an acceptable finished appearance. Issues to be taken into account include:

- a) plastering and dry lining
- b) walls
- c) ceilings
- d) skirtings.

#### Plastering and dry lining

Plastered and dry lined surfaces should:

- not have board joints readily visible and be within a maximum  $\pm 3\text{mm}$  deviation, measured using a 450mm straight edge with equal offsets
- be viewed from a distance of 2m in natural daylight with no artificial light shining on the surface. Wall lights and/or uplighters should be switched off.

#### Walls

Walls should:

- be reasonably uniform, although there may be minor textural differences around lights and other fittings
- have no visible gaps between fittings and the surface (eg around switch plates)
- have jointing tape fully covered and unobtrusive in the finished surface
- have flat walls and within a  $\pm 3\text{mm}$  deviation measured using a 2m straight edge with equal offsets
- be a maximum of 8mm from plumb for walls up to 3m high. Taller walls should be a maximum of 8mm from plumb per storey and 12mm in total.

Figure 7: Straightness of internal walls in section

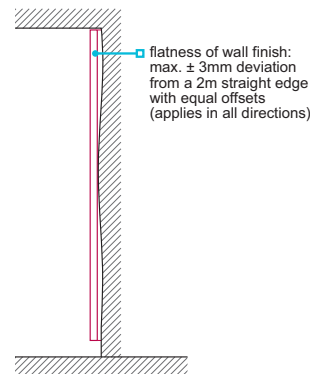
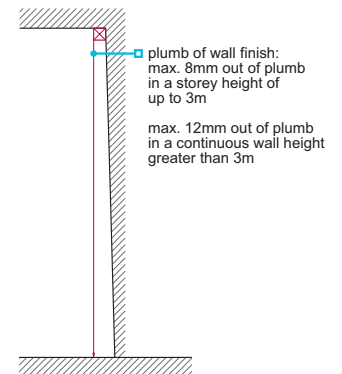

Figure 8: Plumb of internal walls



#### Ceilings

Ceilings should be:

- level within a 3mm deviation per 1m for ceilings up to 6m across (measured at the furthest points across the full width of the ceiling)
- a maximum of 20mm out of level for ceilings over 6m across
- flat within a  $\pm 5\text{mm}$  deviation, measured using a 2m straight edge with equal offsets.

Figure 9: Level and flatness of ceilings

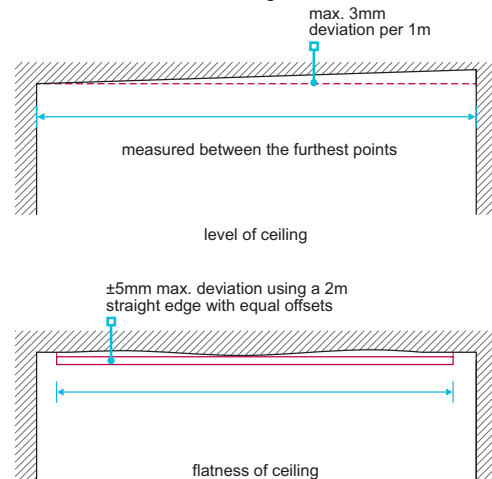

Setting out of corners, duct casings, access covers and any associated framing should be:

- square
- neat and tidy
- provided with an appropriate decorative finish.

Figure 10: Tolerances for external corner details

### Tolerances for corner details

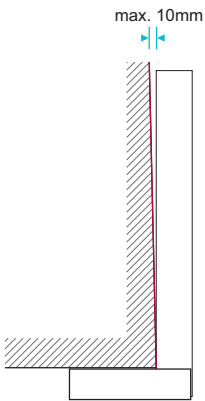

±10mm max. deviation from square in 500mm

Figure 11: Tolerances for internal corner details

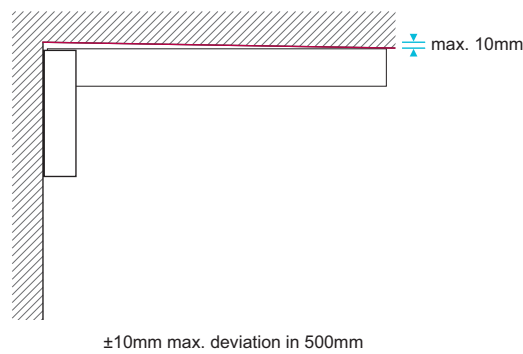

±10mm max. deviation in 500mm

Figure 12: Tolerances for boxings

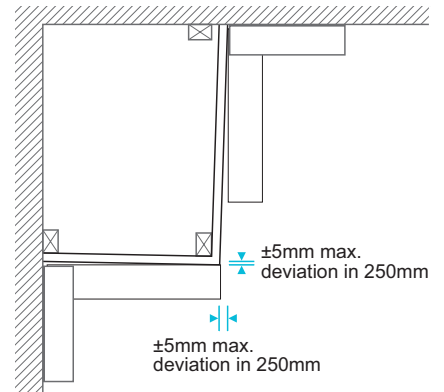

±5mm max. deviation in 250mm

±5mm max. deviation in 250mm

### Also note:

- in plastered walls and ceilings, some tooling marks may be visible
- some cracking (up to 2mm wide) may occur at wall, floor and ceiling junctions, due to shrinkage and differential movement of materials
- small cracks may occur in wall finishes which pass across floors (eg in staircase walls)
- where stair strings abut a wall, a crack of up to 4mm may appear as a result of shrinkage of materials.

## Skirtings

### Where skirtings are installed:

- the gap between the floor finish (without coverings) and the bottom of the skirting should not exceed 5mm at the time of completion
- joints should present a continuous appearance when viewed from a distance of 2m in daylight (some initial shrinkage of the skirting may already be evident at completion of the property).

### Also note:

- the gap between the floor finish and the skirting may increase due to normal drying out, shrinkage and/or deflection, particularly in timber floors
- gaps may appear at joints and corners due to shrinkage, and between the wall finish and skirting due to drying out, shrinkage and fixing position.

## 9.1.4 Doors and windows

**Doors and windows shall be installed to appropriate tolerances, including openings in walls and external openings viewed from the inside.**

### Internal openings in walls should:

- be flat along the length of sills and window boards, with a maximum deviation of ±3mm in every 2m
- have level heads and sills, a maximum of 3mm from level for openings up to 1.5m, and 5mm where longer
- have plumb reveals, a maximum of 3mm from plumb for openings up to 1.5m high, and 5mm where higher
- be level within 3mm across the sill measured from the frame (tiled sills, in bathrooms, for example, may be intentionally laid sloping away from the window)
- be square with the window, with a maximum deviation of ±5mm for reveals up to 250mm deep.

### Window frames should not be distorted in the opening, and a maximum from plumb of:

- 3mm when up to 1.5m in height
- 5mm when larger.

Figure 13: Tolerances for internal openings

**Tolerances for internal openings**

head and sill: max. 3mm out of level for openings up to 1.5m wide  
max. 5mm out of level for openings over 1.5m wide

± 5mm max. deviation of square for reveals up to 250mm deep

max. 3mm out of level across reveal (measured from frame)\*

reveals: max. 3mm out of plumb for openings up to 1.5m high  
max. 5mm out of plumb for openings over 1.5m high

\*tiled sills, in bathrooms, for example, may be intentionally laid sloping away from the window

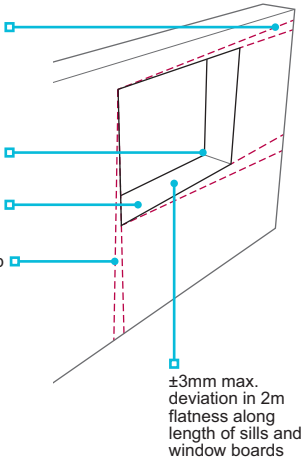

Figure 14: Tolerances for windows

**Tolerances for windows**

window distortion: max. 3mm out of plumb for windows less than 1.5m high

max. 5mm out of plumb for windows over 1.5m high

frames should not be distorted in the opening

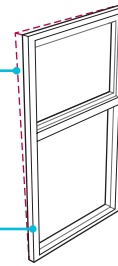

### Internal doors

Internal doors and frames should always be installed in accordance with the manufacturer's recommendations, not be distorted in the opening, and:

- frames should be within 5mm of plumb over the height of the frame and not out of plumb in two directions
- the gap between the door and head or jamb should be a maximum of 4mm (for double doors, the gap at the meeting stiles should be within 4mm) and uniform
- distortion across doors should be limited to a maximum of 5mm in height, and 3mm in width
- the gap between the underside of the door and unfinished floor should be between 10mm and 22mm. The ventilation requirements for the building need to be taken into account when determining the gap beneath internal doors.

Figure 15: Tolerances for internal doors

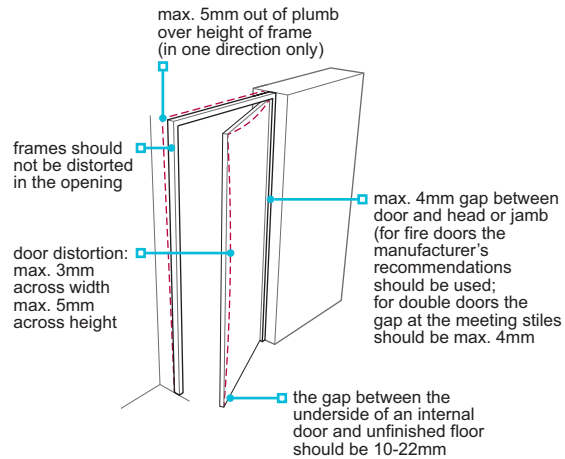

### Fire doors

Fire doors should be installed in accordance with the manufacturer's recommendations. The tolerances in this clause are without prejudice to satisfactory performance for ventilation and fire resistance.

### External doors

External doors and frames should be installed in accordance with the manufacturer's recommendations, not be distorted in the opening, and:

- frames should be within 5mm of plumb over the height of the frame and not be out of plumb in two directions
- distortion across the door should be limited to a maximum of 5mm in height and 3mm in width.

## 9.1.5 Floors

**Floors shall be built to appropriate tolerances.**

Floors should be:

- level within a 3mm deviation per 1m for floors up to 6m across (measured at the furthest points across the full width of the floor)
- a maximum of 20mm out of level for floors over 6m across
- flat within a ±5mm deviation, measured using a 2m straight edge with equal offsets.

Underfloor service ducts should be constructed so that the cover is level with the adjacent floor finish. The selection of floor finish should take into account that drying shrinkage of the floor may result in minor differences in level between the floor and duct cover, which may be more evident with some types of thin floor coverings.

### 9.1.6 Glazing

#### Glass shall be free from undue defects.

Glass should be checked in daylight, from within the room and from a minimum distance of 2m (3m for toughened, laminated or coated glass). The following are acceptable where they are not obtrusive or bunched:

- bubbles or blisters
- hairlines or blobs
- fine scratches not more than 25mm long
- minute particles.

The above does not apply to areas within 6mm of the edge of the pane, where minor scratching may occur.

### 9.1.7 Ceramic, concrete, terrazzo and similar tile finishes

#### Ceramic, concrete, terrazzo and similar tile finishes shall have an appropriate appearance.

For ceramic, concrete, terrazzo and similar tile finishes:

- joints should be straight and in alignment, unless the tiles are, by design, irregular in shape
- wall tile joints should be a minimum of 1.5mm for ceramic tiles, 2mm for smooth natural stone tiles and 6mm for textured tiles, unless otherwise specified by the manufacturer
- floor tile joints should be a minimum of 3mm and proportionally wider for larger tiles, unless otherwise specified by the manufacturer
- joints in floor tiles should generally not exceed the tile thickness, although wider joints up to 10mm may be necessary to accommodate dimensional irregularities in some tiles
- should limit the effect of dimensional irregularities, with joints suitably arranged to maintain a regular appearance
- the variation in surface level should be within  $\pm 3$ mm measured using a 2m straight edge with equal offsets
- the variation in surface level between adjacent tiles should be 1mm or less where the joint is up to 6mm wide, or 2mm or less where the joint is over 6mm wide.

### 9.1.8 Fitted furniture

#### Fitted furniture shall have an appropriate appearance.

Fitted furniture, including doors and drawers, should:

- be visually aligned (vertically, horizontally and in plan), and there should not be significant differences in level at the intersection of adjacent worktops
- operate as intended by the manufacturer
- have uniform gaps between adjacent doors and/or drawers where appropriate
- not have conspicuous abrasions or scratches on factory-finished components when viewed in daylight from a distance of 0.5m.

Also note:

- no dimensional tolerance has been set for gaps between adjacent doors and/or drawers or for their alignment, because some variation will be necessary to take account of adjustments as part of the fitting process
- no dimensional tolerance has been set for the abutment of adjacent worktops due to the variety of materials available and because minor variations, even with manufactured products, are inevitable and small differences in height may be unavoidable
- fitted furniture should be viewed from a distance of 0.5m
- conspicuous surface abrasions caused during installation should be removed in accordance with the manufacturer's recommendations, which may include filling, polishing out, respraying or painting as appropriate
- in rooms or areas where there is no daylight, scratches should be viewed in artificial light from fixed wall or ceiling outlets and not from portable equipment
- kitchen units should not delaminate, including those located near hobs and extractor fans.



### 9.1.9 Joint sealants

**Joint sealants shall have a neat and tidy appearance.**

Sealants should be tooled to:

- remove blisters and irregularities
- achieve a compact, smooth neat surface finish.

Also note:

- joints should be viewed from a distance of 2m, where possible, depending on the location (eg showers and baths may make this impossible).

### 9.1.10 Paint finishes

**Painted and varnished surfaces shall be even in appearance and free from conspicuous runs and prominent brush marks.**

Painted and varnished surfaces should:

- be reasonably smooth and free from nail holes, cracks and splits
- have joints filled
- be reasonably uniform in colour, texture and finish.

Also note:

- surfaces should be viewed in daylight from a distance of 2m and not by shining artificial light on the surface. Wall lights and/or uplighters should be switched off
- timber surfaces may show limited raised grain, and the colour and texture may also vary
- drying shrinkage of timber may cause cracking of the paint finish, particularly where joints occur in plaster and woodwork
- where painted surfaces are touched up, minor colour variations may occur
- external finishes will dull over time, depending on a number of factors such as exposure to sunlight, rain and pollutants
- resin can exude from knots, causing discoloration of paintwork, even though modern primers contain a compound to limit this
- site-decorated trim, such as architrave and skirting, may have a different finished appearance from factory-finished components, such as doors.

### 9.1.11 Sanitary ware

**Baths, shower trays and basins shall be free from scratches, chips and other damage at the time of handover.**

Sanitary fittings, such as baths, shower trays and basins, should not have conspicuous abrasions, scratches or chips when viewed in daylight from a distance of 0.5m.

Also note:

- in rooms or areas where there is no daylight, scratches should be viewed in artificial light from fixed wall or ceiling outlets and not from portable equipment.

### 9.1.12 Other surfaces and components

**Other surfaces and finishes shall have an appropriate appearance.**

Other surfaces and finishes, such as fascia boards, meter cabinets and radiators, should:

- be reasonably smooth and free from nail holes, cracks and splits
- have joints filled
- be reasonably uniform in colour, texture and finish.

### 9.1.13 Pitched roof coverings

**Pitched roof coverings shall have an acceptable finished appearance.**

Tiles and slates should:

- be reasonably uniform in texture, finish and colour
- be suitably mixed to avoid excessive colour banding.

Also note:

- some minor blemishes will occur on individual tiles and slates
- some minor variations will occur in the texture, finish and colour of individual tiles and slates
- efflorescence occurs naturally on some types of tile. It is not harmful and generally disappears over time. Tiles which have efflorescence when laid should be suitably mixed to avoid a patchy appearance.

### 9.1.14 Garages

**Garages shall have an acceptable appearance.**

Garage walls, floors and roofs should be built to appropriate tolerances.

Also note:

- cracks up to 2mm wide in unplastered blockwork walls may be evident due to thermal movement and shrinkage
- garage floors may be installed with falls for drainage or fire separation. Where garage floors have not been sealed, dusting may occur
- the effects of normal drying shrinkage of concrete floors could cause some small gaps around the perimeter at wall junctions.

### 9.1.15 External works

**External works, including drives and paths, shall have appropriate finishes.**

Drives and paths should be:

- within a maximum  $\pm 10$ mm deviation measured using a 2m straight edge with equal offsets; however, localised falls into gulleys and channels are acceptable
- designed and constructed to minimise the potential for standing water.

One hour after rain has stopped, areas of temporary standing water should not be deeper than 5mm or exceed 1m<sup>2</sup>. Temporary standing water is not permitted adjacent to entrance doors.

Also note:

- displacement and variations in surface levels, including scuffing and pitting, may arise due to settlement, natural ground movement and traffic
- when checking flatness, the slope required for drainage on drives should be taken into account.

Drainage covers should:

- align with the adjacent ground or surface finish (for channels, the cover should be set below the adjacent ground)
- be positioned so that the difference in height between the cover and adjacent hard surfaces allows for future settlement.

### 9.1.16 Further information

Roof Tile Association Guidance - A developer and contractor guide to achieving the best visual effect with roof tiles manufactured from concrete and clay. Issue 1 August 2023.

Figure reference table

Figure reference table 9.1			
Fig No	Title/Description	Clause	Page
Figure 1	Straightness in plan for fair faced masonry	9.1.2	2
Figure 2	Straightness in section for fair faced masonry	9.1.2	2
Figure 3	Plumb in section for fair faced masonry	9.1.2	2
Figure 4	Straightness at reveals for fair faced masonry	9.1.2	2
Figure 5	Straightness of bed joints in fair faced masonry	9.1.2	2
Figure 6	Straightness in section for render	9.1.2	3
Figure 7	Straightness of internal walls in section	9.1.3	4
Figure 8	Plumb of internal walls	9.1.3	4
Figure 9	Level and flatness of ceilings	9.1.3	4
Figure 10	Tolerances for external corner details	9.1.3	5
Figure 11	Tolerances for internal corner details	9.1.3	5
Figure 12	Tolerances for boxings	9.1.3	5
Figure 13	Tolerances for internal openings	9.1.4	6
Figure 14	Tolerances for windows	9.1.4	6
Figure 15	Tolerances for internal doors	9.1.4	6