

## Substructure and ground bearing floors

This chapter gives guidance on meeting the Technical Requirements and recommendations for substructures (excluding foundations), including: substructure walls, ground bearing floors where infill is no deeper than 600mm, and installation of services below the damp proof course (DPC).

|        |                                      |    |
|--------|--------------------------------------|----|
| 5.1.1  | Compliance                           | 01 |
| 5.1.2  | Provision of information             | 01 |
| 5.1.3  | Transfer of loads                    | 01 |
| 5.1.4  | Ground conditions                    | 01 |
| 5.1.5  | Services and drainage                | 02 |
| 5.1.6  | Ground below fill                    | 03 |
| 5.1.7  | Fill below floors                    | 03 |
| 5.1.8  | Infill up to 600mm deep              | 04 |
| 5.1.9  | Materials used for fill              | 04 |
| 5.1.10 | Harmful or toxic materials           | 04 |
| 5.1.11 | Regulatory solutions                 | 05 |
| 5.1.12 | Walls below DPC                      | 05 |
| 5.1.13 | Durability                           | 06 |
| 5.1.14 | Mortar                               | 07 |
| 5.1.15 | Wall ties                            | 07 |
| 5.1.16 | Blinding                             | 07 |
| 5.1.17 | Ground floor slab and concrete       | 07 |
| 5.1.18 | Laying the ground-bearing floor slab | 08 |
| 5.1.19 | Damp proof course                    | 08 |
| 5.1.20 | Damp proofing concrete floors        | 09 |
| 5.1.21 | Thermal insulation                   | 09 |
| 5.1.22 | Installation of insulation           | 10 |
| 5.1.23 | Further information                  | 10 |

For figure reference tables in this chapter, please go to the end of the chapter



### 5.1.1 Compliance

*Also see: Chapter 2.1*

#### **Substructures and ground-bearing floors shall comply with the Technical Requirements.**

Substructures and ground-bearing floors that comply with the guidance in this chapter will generally be acceptable.

Ground-bearing floors may only be used where the depth of infill is less than 600mm deep and properly compacted.

### 5.1.2 Provision of information

#### **Designs and specifications shall be produced in a clearly understandable format, include all relevant information and be distributed to appropriate personnel.**

Design and specification information should be issued to site supervisors, relevant specialist subcontractors and suppliers, and include the following information:

- plan dimensions and levels which should be related to benchmarks
- the required sequence and depth of trench backfill where relevant to the design of the walls below the DPC
- details of trench backfill, infill and void formers
- work required to maintain the integrity of DPCs and damp proof membranes (DPMs)
- information on proposed underground services, including points of entry to the building
- detailing of service penetrations through the substructure, including support of the structure above details of junctions between the DPM, DPC and tanking
- details of underfloor, floor edge and cavity insulation
- details of ground hazards and mitigation measures.

### 5.1.3 Transfer of loads

*Also see: Chapters 4.1, 4.3, 5.2 and 6.1*

#### **Substructures and ground-bearing floors shall ensure that loads are supported and transferred to the foundations, or ground, without undue movement.**

The design of the substructure should take account of findings from the site investigation. Where infill deeper than 600mm is needed, a suspended floor should be used.

Load-bearing partitions should have proper foundations and not be supported off ground-bearing floors. In Scotland, sleeper walls should not be built on ground-bearing floors.

### 5.1.4 Ground conditions

*Also see: Chapters 4.1, 4.2, 5.2, 10.1 and BRE Report 211*

#### **Substructure and ground-bearing floors shall not be adversely affected by ground conditions, and take account of:**

- |                                   |  |
|-----------------------------------|--|
| a) ground hazards                 | d) effect of sloping ground on depth of infill and wall construction |
| b) bearing capacity of the ground | e) site works and construction.                                      |
| c) nature of the ground           |  |

#### **Ground hazards**

Hazards likely to affect substructure and ground-bearing floors include contaminated materials, waterlogged ground and chemicals, particularly sulfates.

Where it is necessary to reduce the entry of hazardous gas, which should be identified in the site investigation, such precautions should be acceptable to NHBC.

#### **Bearing capacity**

Ground-bearing floors may not be suitable where the bearing capacity and nature of the ground varies, even where the depth of infill is less than 600mm. Special measures may be needed to restrict settlement, such as the use of suspended floor construction.

#### **Nature of the ground**

Where there is shrinkable soil, expansive materials or other unstable soils, suspended floor construction may be necessary.

Shrinkable soils are classified as those which contain more than 35% fine particles (silt and clay) and which have a Modified Plasticity Index of 10% or more. A soil testing laboratory should be consulted to verify the Plasticity Index of the soil.

### The effect of sloping ground

Sloping ground may require steps in the substructure and possibly different floor levels.

Where more than 600mm of infill is required at any point in a self-contained area, the floor over the whole of that area must be of suspended construction.

Construction on steep slopes may involve walls below DPC level acting as retaining walls and should be designed by an engineer where (H) is greater than four times (T) or H exceeds 1m.

- (H) = height difference between floor/ground levels
- (T) = the total thickness of the retaining wall.

Figure 1: Substructure on sloping ground

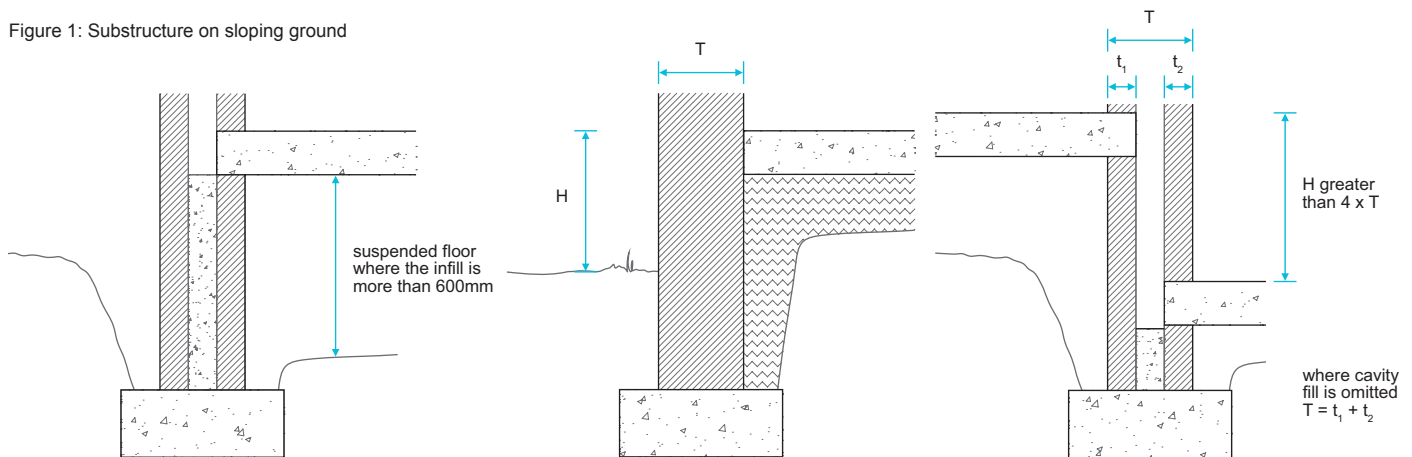

### Site works and construction

Special precautions may be needed to prevent damage to the substructure from site operations on adjoining ground such as ground treatment, or surcharging due to infill.

### 5.1.5 Services and drainage

Also see: Chapters 5.3, 5.4, 6.2 and 8.1

**Substructure and ground-bearing floors shall be installed to:**

- |   |  |
|---|--|
| a) adequately protect existing services and ground water drainage | b) have suitable surface and subsoil drainage      |
|   | c) make allowance for drainage and other services. |

### Adequately protect existing services and ground water drainage

All existing services should be located and identified before work commences. During dry periods it can be difficult to determine if ground water drains are active, so where they are severed or disturbed, they should be reconnected to a suitable outfall.

Existing active groundwater drainage should be retained to minimise the risk of flooding. Water from these drains may require diverting.

Where existing services conflict with the proposed foundations or substructure, and they are to remain, they should be protected or diverted and remaining voids filled with concrete or grout. Where they are no longer active and are not needed, they should be disconnected and removed.

Figure 2: Diversion of existing services

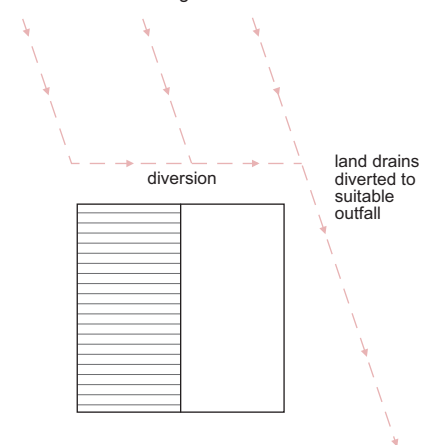

### Surface water and subsoil drainage

Surface and/or subsoil drainage may be needed on sites where there is a risk of waterlogging.

Walls which act as retaining walls may require land drains, hardcore fill and suitable outlets to dispose of any subsoil water that collects behind the wall.

Ground or paths adjoining the home should:

- slope away at a slight fall
- generally be at least 150mm below the DPC.

### Make allowance for drainage and other services

Design information should include all necessary details relating to the proposed underground services.

Drain pipes passing through or under the building may require flexible connections or other means of accommodating differential movement.

Pipes passing through substructure walls should accommodate movement by:

- a 50mm clearance all round, or
- a sleeve, with 50mm clearance all round and suitably sealed, or,
- bedded pipes, connected on both sides of the wall with flexible joints located as close as is feasible to the outside face of the wall but at a maximum of 150mm from the face of the wall.

Flexible joints should be made in accordance with the pipe manufacturer's recommendations.

Figure 3: Pipes bedded in walls with flexible joints

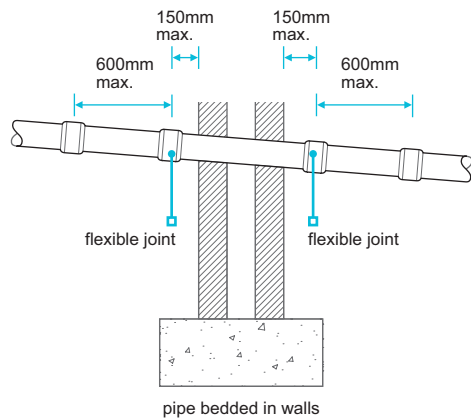

Figure 4: Pipes passing through a lintelled opening

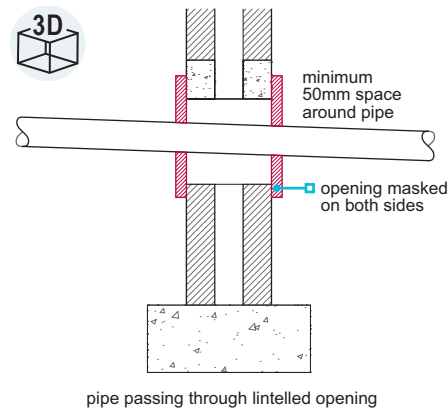
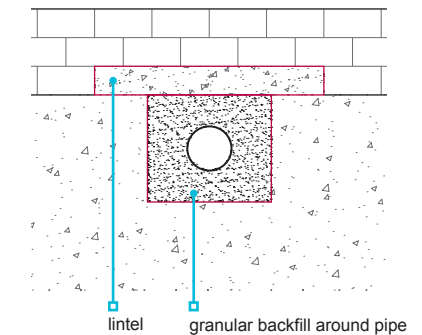

Figure 5: Backfill around pipes within openings



Where required, they should be arranged so that future access can be obtained without affecting structural stability.

When unidentified services, ducts, cables or pipes are exposed, advice should be sought from local offices of statutory undertakings and service supply companies.

### 5.1.6 Ground below fill

**Ground below fill shall be adequately prepared to provide consistent support to the fill and the ground-bearing slab without undue movement.**

Ground-bearing floor slabs may only be built on ground where:

- the ground is suitable to support floor loads and any other loads
- all topsoil containing vegetation and organic matter, including tree roots, has been removed
- there is a suitable and even bearing surface.

### 5.1.7 Fill below floors

**Fill, including made ground, trench backfill and infill below ground-bearing floor slabs shall provide full and consistent support to ground-bearing slabs.**

Where more than 600mm of infill is required at any point within a self-contained area, or the bearing capacity and nature of the ground varies, the floor over the self-contained area should be of suspended construction.

Infill under slabs and backfill in trenches should be properly placed and mechanically compacted to form a stable mass in layers not exceeding 225mm. Concrete may be used as an alternative to backfill in trenches.

Figure 6: Infill under slab and backfill in trenches

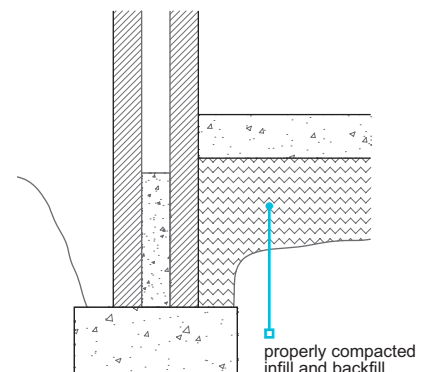

### 5.1.8 Infill up to 600mm deep

Also see: Chapter 5.2

**Infill beneath ground-bearing floors shall be a maximum of 600mm deep.**

Ground-bearing slabs are not acceptable where infill exceeds 600mm in depth.

Where the design requires in excess of 600mm of infill at any point within a self-contained area, the floor construction over the whole of that area is required to be independent of the fill and capable of supporting:

- self-weight
- non load-bearing partitions
- other imposed loads.

Generally this should be achieved with the use of a suspended slab. See Chapter 5.2.

### 5.1.9 Materials used for fill

Also see: Chapter 4.6, BRE DG 522 'Hardcore for supporting ground floors of buildings'

**Materials used for fill shall be suitable for the intended use and, unless appropriate precautions are taken, free from hazardous materials. Issues to be taken into account include:**

a) sources of fill materials

b) hazardous materials.

Fill should be:

- well graded
- inert and contain no hazardous materials
- able to pass a 150mm x 150mm screen in all directions.

Fill containing either expansive materials or chemicals is not acceptable for the support of ground-bearing slabs.

The following types of fill should not be used unless written permission has been obtained from NHBC:

- material obtained from demolition
- furnace ashes and other products of combustion
- colliery shale and any other residue from mineral extraction
- slags
- on wet sites, or sites with a high water table, crushed or broken bricks which have S1 designation according to BS EN 771.

#### Sources of fill material

Where the material is of a stable and uniform type, and from one source, it may only be necessary to check its suitability once. Where material is variable, or from a number of sources, it should all be suitable, and regular inspections and/or testing may be required.

Where industrial waste is permitted as fill material, it is essential that sufficient testing is carried out to ensure suitability.

Where material is obtained from stockpiles, check the material is uniform. Different forms of stockpiling can affect particle size/grading. The outside of a stockpile may be weathered and may not be the same as unweathered material.

#### Hazardous materials

The following fill materials require testing to ensure their suitability for use with ground-bearing slabs or as backfill to associated trenches:

- reactive materials
- organic materials
- toxic materials
- materials that include sulfates, eg gypsum
- materials that cause noxious fumes, rot, undue settlement or damage to surrounding materials
- acid wastes.

### 5.1.10 Harmful or toxic materials

Also see: BRE DG 522 'Hardcore for supporting ground floors of buildings'

**Harmful or toxic materials present in the fill or in the ground shall be identified to the satisfaction of NHBC and not affect the performance of the substructure and ground-bearing slab.**

Precautions should be taken by either:

- ensuring that made ground and fill materials are free from harmful or toxic substances, or
- designing the construction to contain, resist and prevent the adverse effects of such materials, using means acceptable to NHBC.

Tests for sulfate content should comply with the recommendations of BRE Special Digest 1 Third Edition by a suitably qualified person who has a detailed knowledge of the:

- material being tested
- proposed conditions of use.

The samples tested must be representative of the material, so it may be necessary to collect multiple samples to identify characteristics.

Where there are likely to be harmful levels of sulfate:

- the floor slab should be of an appropriate mix to resist sulfate attack or be protected by an impervious layer of 1200 gauge (0.3mm) polyethylene sheet, or 1000 gauge (0.25mm) where it complies with Technical Requirement R3. This may also serve as a DPM
- the concrete blocks in substructure walls should be sulfate resistant and suitable for the fill and ground conditions
- the mortar should be sulfate resisting to comply with BS EN 1996-1-1.

Fill containing expansive materials or chemicals is not acceptable for use as infill or backfill.

### 5.1.11 Regulatory solutions

**Use of recycled or secondary materials shall comply with the relevant waste regulatory requirements.**

**Table 1:** Regulatory solution for fill, including recycled and secondary materials

| Location                      | Materials used on               | Regulatory solution  |
|-------------------------------|---------------------------------|--|
| England and Wales             | Site of origin                  | CL:AIRE Code of Practice   |
|                               | Other sites and less than 5000t | Registration under a U1 exemption with the EA is required at the receiving site                  |
|                               | Other sites and over 5000t      | Ensure that the supplier has followed the WRAP protocol  |
| Northern Ireland and Scotland | Any site                        | Registration under a paragraph 19 exemption with the SEPA/NIEA is required at the receiving site |

EA: Environment Agency  
CL:AIRE: Contaminated Land: Applications in Real Environments

NIEA: Northern Ireland Environment Agency  
SEPA: Scottish Environment Protection Agency

### 5.1.12 Walls below the DPC

*Also see: Chapters 6.1 and 6.2*

**Substructure and walls below the DPC shall be suitably constructed. Issues to be taken into account include:**

- construction of walls acting as temporary retaining walls
- concrete cavity fill.

#### Construction of walls acting as temporary retaining walls

Backfill should be placed in layers of equal thickness to both sides of the substructure walls, so that compaction on one side is not more than one layer ahead of the other. Where backfill is placed and compacted on one side of the foundation trench before the other side is backfilled, the wall will be acting as a temporary retaining wall.

In such cases, the wall should either be designed by an engineer in accordance with Technical Requirement R5 or the thickness (T) should be as indicated in Table 2.

Figure 7: Substructure walls acting as temporary retaining walls

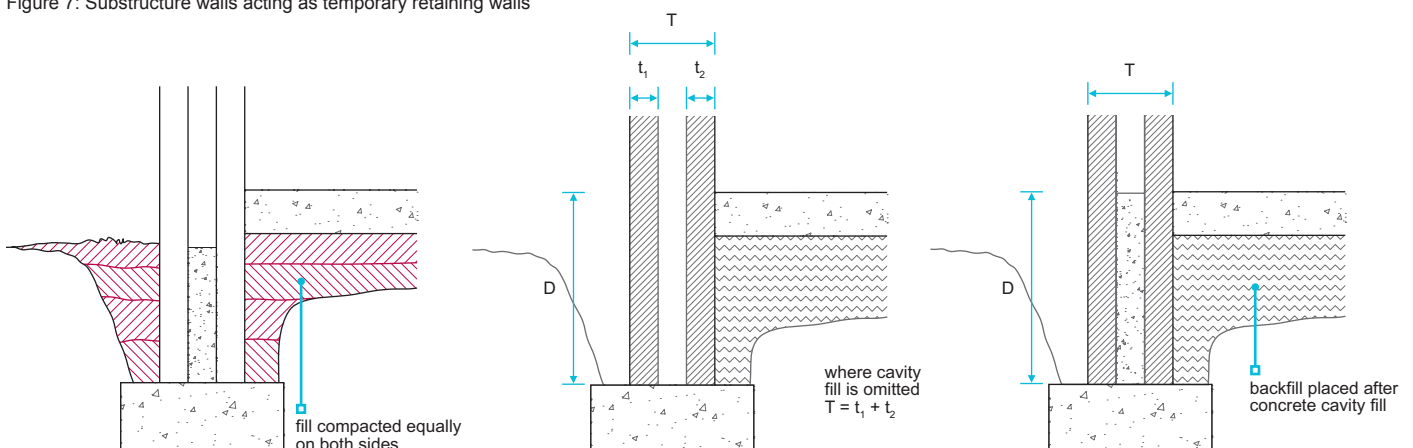

**Table 2:** Acceptable D:T of temporary retaining walls

| Depth (D) of filled trench | Minimum thickness (T) of wall leaf supporting fill |
|----------------------------|--|
| Up to 1100mm               | 200mm  |
| 1100-1400mm                | 300mm  |
| 1400-1700mm                | 400mm  |
| 1700-2000mm                | 500mm  |

This guidance is only applicable to the temporary condition and where problems such as hydrostatic pressure are not present.

### Concrete cavity fill

A minimum 225mm clear cavity below the DPC should be maintained. When specialised foundations are used, including those for timber framed buildings, the minimum clear cavity depth may be reduced to 150mm below the DPC, provided that weepholes and other necessary measures are taken to ensure free drainage. For further guidance see Clause 4.4.13.

### 5.1.13 Durability

*Also see: Chapters 4.3, 6.1 and BS EN 1996-1-1*

**Substructure and walls below the DPC shall be capable of supporting their intended loads and, where necessary, be resistant to frost action, sulfates and other harmful or toxic materials. Issues to be taken into account include:**

- a) brickwork
- b) blockwork.

Frost damage occurs on saturated masonry exposed to freezing conditions. Bricks, blocks and mortars located 150mm above and below ground level are the most likely to be damaged by frost.

Masonry walls below the DPC should be designed and constructed as described in Chapter 6.1 'External Masonry Walls'.

Recommendations for the design strength of bricks, masonry blocks and mortars are given in BS EN 1996-1-1.

#### Brickwork

Bricks should be of suitable durability, especially in the outer leaf below the DPC, or where they could be frozen when saturated. Bricks used in retaining walls should be suitable for the exposure and climate, as recommended by the manufacturer.

Clay bricks should comply with BS EN 771, which classifies bricks according to their durability designation (F) and to the content of active soluble salts (S).

|    |   |
|----|---|
| F0 | Not freeze/thaw resistant and should not be used externally |
| F1 | Moderately freeze/thaw resistant                            |
| F2 | Freeze/thaw resistant                                       |
| S1 | Normal active soluble salts                                 |
| S2 | Low active soluble salts                                    |

Generally, bricks are designated to F1,S2 or F1,S1. If in doubt as to suitability, bricks of F2,S2 or F2,S1 should be specified, or the manufacturer consulted and written confirmation obtained in relation to:

- geographical location
- location in the structure.

Calcium silicate bricks for use below DPC should be at least compressive strength class 20.

#### Blockwork

Concrete blocks for use below the DPC should meet BS EN 771 and one of the following:

- minimum density of 1500kg/m<sup>3</sup>, or
- assessed in accordance with Technical Requirement R3.
- minimum compressive strength of 7.3N/mm<sup>2</sup>, or

Where it is necessary to resist sulfate attack and ensure adequate durability, blocks made with sulfate-resisting cement and/or a higher than normal cement content should be used.

Where there is doubt regarding the suitability of the block, particularly where acids or sulfates occur, written confirmation of its suitability should be obtained from the manufacturer in relation to:

- geographical location
- location in the structure.

### 5.1.14 Mortar

*Also see: Chapter 6.1*

**Substructure and walls below DPC level shall use mortar which is suitable for the location and intended use. Issues to be taken into account include:**

a) mortar mix

b) sulfate resistance.

#### Mortar mix

Mortar should comply with the design and should take account of the strength, type and location of the masonry. The selection of mortar for use below the DPC should follow the recommendations given in BS EN 1996-1-1.

The use of proprietary mortars and admixtures should:

- account for the type of masonry unit and its location
- only be used in accordance with the manufacturer's recommendations.

For non-clay bricks or blocks, mortar should be used in accordance with the brick manufacturer's recommendations.

#### Sulfate resistance

Cements which resist sulfates should be used where:

- sulfates are present in the ground, ground water or masonry
- recommended by the brick manufacturer.

In such cases, cements which resist sulfates to BS EN 197 should be used.

### 5.1.15 Wall ties

**Substructure and walls below the DPC shall use wall ties suitable for their intended use.**

Wall ties should comply with BS EN 845-1 or be assessed in accordance with Technical Requirement R3.

Where cavity insulation batts or slabs start below DPC level, the vertical and horizontal spacing of wall ties should be compatible with the spacing to be used above DPC level.

### 5.1.16 Blinding

**Blinding shall provide a suitable surface for the materials above.**

Infill should be sufficiently blinded to receive the concrete, and DPM where required, using the minimum thickness necessary to give a suitable surface.

Concrete blinding may be needed where voids in the fill could result in loss of fines from the blinding. Where hardcore fill is used, smooth blinding, eg sand or other suitable fine material, is essential to avoid puncturing a sheet DPM.

Where the ground floor is to be reinforced, blinding should be firm and even, to give good support for the reinforcement and to maintain the design cover using reinforcement stools, where appropriate.

### 5.1.17 Ground floor slab and concrete

*Also see: Chapter 3.1*

**Ground-bearing floors shall be of adequate strength and durability, and use concrete mixed and reinforced as necessary to support floor loads safely and resist chemical and frost action.**

Ground-bearing concrete floor slabs should be at least 100mm thick, including monolithic screed where appropriate.



### 5.1.18 Laying the ground-bearing floor slab

Also see: Chapters 3.1 and 9.3

**Ground-bearing floors shall be reasonably level and effectively impervious to moisture.**

All underfloor services and ducts should be installed and tested before concreting, where appropriate.

Care should be taken to ensure that all joints and junctions between DPMs, wall DPCs or tanking in substructure walls are undamaged, especially while the concrete for the ground slab is being poured.

Figure 8: DPM/DPC protected during installation of a concrete slab

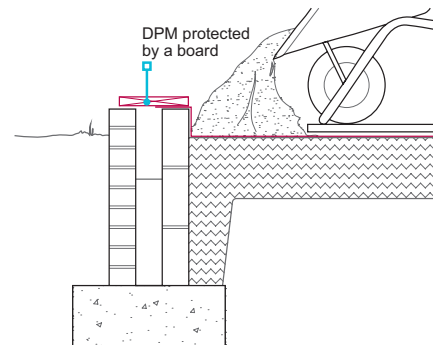

### 5.1.19 Damp proof course

Also see: Chapters 5.4, 6.1 and 6.3

**Damp proof courses shall adequately resist moisture from reaching the inside of the building. Issues to be taken into account include:**

a) positioning of DPCs

b) DPC materials.

#### Positioning of DPCs

DPCs should be:

- positioned a minimum of 150mm above external finished ground or paving level
- linked with any DPM
- of the correct width and fully bedded
- either welded or lapped by 100mm minimum
- impermeable.

Figure 9: DPC at least 150mm above finished ground level

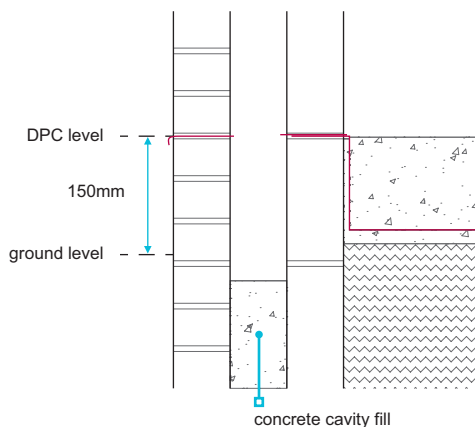
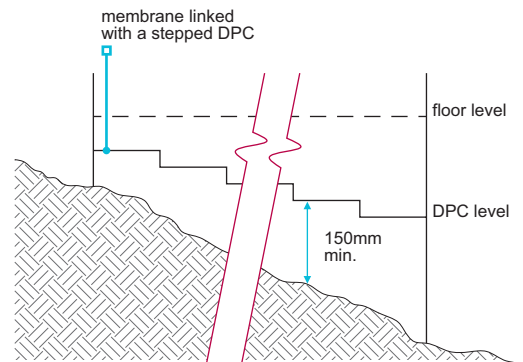

Figure 10: Stepped DPC levels on sloping sites



Where homes are 'stepped' on a sloping site, care should be taken to link DPCs and DPMs so that all parts of each home are protected.

#### DPC materials

Acceptable materials for DPCs include:

|   |                          |
|---|--------------------------|
| <b>Bitumen based materials</b>  | BS 6398<br>BS EN 14967   |
| <b>Polyethylene, (should not be used below copings, in parapets or for tanking)</b> | BS 6515<br>BS EN 14909   |
| <b>Proprietary materials</b>  | Technical Requirement R3 |

DPCs and flexible cavity trays should be of the correct dimensions. At complicated junctions, preformed cavity trays of the correct type and shape should be used.

Brick DPCs are only suitable to resist the upward movement of moisture and should:

- consist of two courses of engineering bricks, laid broken bond
- be bedded and jointed in a 1:¼:3, cement:lime:sand, or equivalent, mortar.

### 5.1.20 Damp proofing concrete floors

**Ground-bearing floors shall resist the passage of moisture to the inside of the home.**

Ground-bearing concrete floor slabs should be protected against ground moisture by providing a continuous damp proof membrane (DPM). The DPM should:

- have sealed laps of at least 300mm wide
- link with wall DPCs to form an impervious barrier to prevent moisture reaching the interior of the dwelling
- take account of possible differential movement.

Care should be taken not to trap moisture when a combination of damp proofing and vapour control layers are used.

When the DPM is located below the slab, a blinding layer of sand should be provided to fill voids in the hardcore and to minimise the risk of puncturing the membrane.

A clear cavity of at least 225mm below the DPC should be maintained. When specialised foundations are used, including those for timber framed buildings, this depth may be reduced to 150mm below the DPC where weepholes are provided and other necessary measures are taken to ensure that the cavity can drain freely.

Where homes are stepped down a sloping site, the DPCs and DPMs should be linked so that all parts of each home are protected. The guidance in Chapter 5.4 'Waterproofing of basements and other below ground structures' should be followed where steps between floor slabs are greater than 150mm.

Suitable materials for DPMs include:

- 1200 gauge (0.3mm) polyethylene sheet
- minimum 1000 gauge (0.25mm) polyethylene sheet where it complies with Technical Requirement R3
- bitumen sheet to BS 6398
- materials that comply with Technical Requirement R3.

Figure 11: 225mm clear cavity below DPC

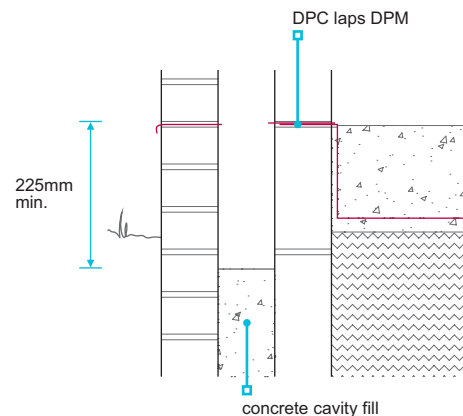

### 5.1.21 Thermal insulation

*Also see: Chapters 6.1, 9.3 and BRE Report 'Thermal insulation: avoiding risks'*

**Ground-bearing floors and walls below the DPC shall be thermally insulated to comply with Building Regulations and be suitable for the intended use. Issues to be taken into account include:**

- |                     |                      |
|---------------------|----------------------|
| a) floor insulation | c) thermal bridging. |
| b) wall insulation  |                      |

#### Floor insulation

Thermal insulation materials for use below ground-bearing slabs should have:

- appropriate density for the location
- low water absorption.

Insulation to be positioned below both the slab and DPM should be resistant to ground contaminants. The following materials are acceptable for use as insulation:

- expanded polystyrene boards (grade EPS 70) to BS EN 13163
- a proprietary material that complies with Technical Requirement R3.

#### Wall insulation

Cavity insulation materials, super lightweight blocks, blocks with face bonded insulation or integral insulation should be:

- manufactured and used to comply with a British Standard and relevant code of practice, or
- used in compliance with Technical Requirement R3.

The thickness of materials for masonry cavity walls should be suitable for the required level of performance, see Clause 6.1.7.

### Thermal bridging

The design should ensure that any risk of thermal bridging is minimised, especially at junctions between floors and external walls. Precautions include:

- extending cavity insulation below floor slab level
- linking floor and wall insulation
- providing perimeter insulation to floors
- facing supporting substructure with insulation – where homes are stepped or staggered, the wall forming the step or stagger may require insulation
- particular attention should be paid to ensuring thermal bridging is addressed at door openings.

### 5.1.22 Installation of insulation

**Installation of thermal insulation shall ensure that the full thermal performance of the floor is achieved.**

Insulation boards should be tightly butted together to maintain insulation continuity. Where the insulation is turned up vertically at the edge of the slab, it should be protected whilst the concrete is being poured and tamped.

Figure 12: Protection of perimeter insulation board during installation of concrete floor

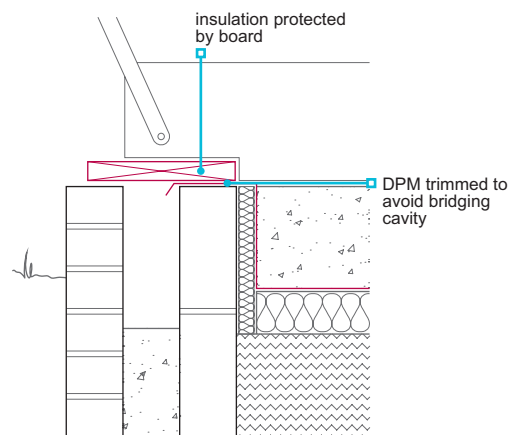

### 5.1.23 Further information

- BRE Digest 433.

### Figure reference table

| Figure reference table 5.1 |  |        |      |
|----------------------------|--|--------|------|
| Fig No                     | Title/Description  | Clause | Page |
| Figure 1                   | Substructure on sloping ground   | 5.1.4  | 2    |
| Figure 2                   | Diversion of existing services   | 5.1.5  | 2    |
| Figure 3                   | Pipes bedded in walls with flexible joints                                     | 5.1.5  | 3    |
| Figure 4                   | Pipes passing through a lintelled opening                                      | 5.1.5  | 3    |
| Figure 5                   | Backfill around pipes within openings  | 5.1.5  | 3    |
| Figure 6                   | Infill under slab and backfill in trenches                                     | 5.1.7  | 3    |
| Figure 7                   | Substructure walls acting as temporary retaining walls                         | 5.1.12 | 5    |
| Figure 8                   | DPM/DPC protected during installation of a concrete slab                       | 5.1.18 | 8    |
| Figure 9                   | DPC at least 150mm above finished ground level                                 | 5.1.19 | 8    |
| Figure 10                  | Stepped DPC levels on sloping sites  | 5.1.19 | 8    |
| Figure 11                  | 225mm clear cavity below DPC   | 5.1.20 | 9    |
| Figure 12                  | Protection of perimeter insulation board during installation of concrete floor | 5.1.22 | 10   |